

SHARE in Orlando

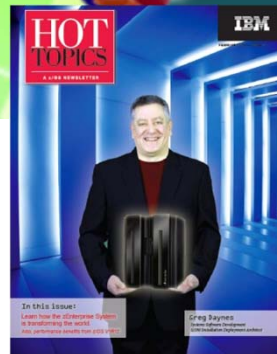

# Everything a System Programmer Needs to Know to Exploit (z196 or z114) Server

Session 10099



**Greg Daynes**  
[gdaynes@us.ibm.com](mailto:gdaynes@us.ibm.com)  
**z/OS Installation and Deployment Architect**

## Agenda

- IBM zEnterprise Overview
- z196 and z114 Support by z/OS Releases
- Migration Considerations
  - General
  - Migration Considerations for Selected Functions
  - Multisystem/Sysplex Considerations
  - Exploitation Considerations for Selected Functions
- Migration Paths
  - General Recommendations and Considerations
  - Recommended Paths for Supported z/OS Releases
- Summary
- Backup
  - Cryptographic Support

## Scope

- **The IBM zEnterprise System is comprised of:**
  - Either the IBM zEnterprise 196 (z196) or the IBM zEnterprise 114 (z114) Central Processing Complex (CPC),
  - the IBM zEnterprise Unified Resource Manager,
  - the IBM zEnterprise BladeCenter Extension (zBX) with
    - Optimizers or IBM blades.
  
- **z/OS platform software requirements for:**
  - Hardware upgrade to a zEnterprise server
    - With or without zBX
  - Install a new zEnterprise server
    - With or without zBX
  
- **Outside scope**
  - z/VM (native), zLinux, and zTPF considerations
  - Non-z/OS software required for zBX solutions

# IBM zEnterprise 196 (z196) System Functions and Features

Five hardware models
Quad-core 5.2 GHz processor chips
Up to 80 processors configurable as CPs, zAAPs, zIIPs, IFLs, ICFs, or optional SAPs (up to 32-way on R7, 64-way on R9, 80-way on R11)
Out of order instruction execution
Improved processor cache design
Up to 15 subcapacity CPs at capacity settings 4, 5, or 6
Up to 3TB real memory (1TB per LPAR)
Improved availability with Redundant Array of Independent Memory (RAIM)
Power save functions
On Demand enhancements
IBM zEnterprise Unified Resource Manager (from HMC)
New and enhanced instructions
Changes to the Common Cryptographic Architecture, Crypto Express3, and Trusted Key Entry
IPL from an alternate subchannel set
PCIe-based I/O infrastructure - - FICON Express8S and OSA Express4S
Large send for IPv6 packets



(z/OS support in blue)  
(Sept 2011 support in red)

Capacity Provisioning enhanced
6.0 GB/sec InfiniBand I/O interrupt
Three subchannel sets per LCSS
FICON Discovery and AutoConfiguration (zDAC)
OSA-Express3 Inbound Workload queueing (IWQ)
IWQ for Enterprise Extender
OSA-Express4S checksum offload for IPv6 and for LPAR to LPAR traffic (both IPv4 and IPv6)
CFCC Level 17 enhancements
Up to 80 External Coupling Link Ports
Up to 128 Coupling Link CHPIDs Defined
Optional water cooling
Optional High Voltage DC power
Optional overhead I/O cable exit
Support for OSX and OSM CHPIDs
zBX-002 IBM Smart Analytics Optimizer
zBX-002 select POWER7 and IBM System x Blades
zBX-002 IBM WebSphere DataPower Integration Appliance X150 for zEnterprise
HiperSockets optimization for intraensemble data networks (SoD)

# IBM zEnterprise 114 Functions and Features (GA)

2 hardware models (M05, M10)
Quad-core 3.8 GHz processor chips
Up to 14 cores with 10 that are user configurable as CPs, zAAPs, zIIPs, IFLs, ICFs, and up to 2 dedicated spares
Out of order instruction execution
Improved processor cache design
Up to 26 subcapacity settings across a maximum of 5 CPs
Up to 248 GB real memory (with an additional 8 GB of fixed memory for the HSA)
Improved availability with Redundant Array of Independent Memory (RAIM)
On Demand enhancements
IBM zEnterprise Unified Resource Manager (from HMC)
New and enhanced instructions
Changes to the Common Cryptographic Architecture, Crypto Express3, and Trusted Key Entry
IPL from an alternate subchannel set
PCIe-based I/O infrastructure - - FICON Express8S and OSA Express4S
Large send for IPv6 packets



(z/OS support in blue)  
(Sept 2011 support in red)

Capacity Provisioning enhanced
6.0 GB/sec InfiniBand I/O interrupt
Two subchannel sets per LCSS
FICON Discovery and AutoConfiguration (zDAC)
OSA-Express3 Inbound Workload queueing (IWQ)
IWQ for Enterprise Extender
OSA-Express4S checksum offload for IPv6 and for LPAR to LPAR traffic (both IPv4 and IPv6)
CFCC Level 17 enhancements
Up to 128 Coupling Link CHPIDs Defined
Optional High Voltage DC power
Optional overhead I/O cable exit
Support for OSX and OSM CHPIDs
zBX-002 IBM Smart Analytics Optimizer
zBX-002 select POWER7 and IBM System x Blades
zBX-002 IBM WebSphere DataPower Integration Appliance X150 for zEnterprise
HiperSockets optimization for intraensemble data networks (SoD)

# Software Line Items – Quality Of Service View

## *Scalability*

Greater than 64 CPs on the server (up to 80)<sup>1</sup>; Greater than 64 CPs on the LPAR (up to 80)<sup>1</sup>; Greater than 1023 CF Structures; Greater than 64 Coupling Link CHPIDs; Power Save Mode support<sup>1</sup>; Three subchannel sets<sup>1</sup>; Removal of the 64k byte data transfer limit for zHPF multitrack operations; **Enable IPL from an alternate subchannel set, up to 32 VLANs per OSA port per stack (for both IPv4 and IPv6); ...**

## *Self Managing Capabilities*

z/OS FICON Discovery and AutoConfiguration (zDAC); IBM zEnterprise Unified Resource Manager; new Guest Platform Management Provider (GPMP) agent; Capacity Provisioning enhancements; New OSA Command – Display OSAINFO; Simplified key management with Trusted Key Entry Workstation (TKE 7.0 LIC); ...

## *Improving Usability and Skills*

Simplified usability with Crypto Express3 migration wizard, ...

The following enhancements have been added to the Common Cryptographic Architecture support which is used in the Crypto Express3 feature when it is configured as a coprocessor: Expanded key support for AES algorithm; Enhanced ANSI TR-31 interoperable secure key exchange; ANSI X9.8 PIN security; PIN block decimalization table protection; Enhance CCA keys wrapping to comply with ANSI X9.24-1 key bundling requirements; Secure key HMAC (Keyed-Hash Message Authentication Code); PKA RSA OAEP with SHA-256 algorithm; Elliptical Curve Cryptography (ECC) Digital Signatures; CP Assist for Cryptographic Function (CPACF) enhancements; 64 Bit; CKDS Constraint Relief; PCI Audit; CBC Key Wrap; and RMF Postprocessor Crypto Activity report support for 4096-bit; **Changes to the Common Cryptographic Architecture, Crypto Express3, and Trusted Key Entry (Expanded support for AES algorithm, enhanced ANSI TR-31 Secure Key Exchange, PIN block decimalization table protection, PKA RSA OAEP with SHA-256 algorithm, and additional Elliptic Curve Cryptography (ECC) functions) ...**

## *Performance*

RSM exploitation of new OPCODEs; HiperDispatch cache and affinity node changes; C/C++ exploitation of new OPCODEs; OSA-Express3 Inbound Workload queueing (IWQ); **new I/O infrastructure to support PCIe – FICON Express8S and OSA Express4S, IWQ for Enterprise Extender, Large send for IPv6 packets, OSA-Express4S checksum offload for IPv6 and for LPAR to LPAR traffic (both IPv4 and IPv6)...**



## *Improving Reliability, Availability, and Serviceability (RAS)*

HiperDispatch performance and serviceability enhancements; Non-disruptive CF dump; CPU Measurement Facility (Hardware Instrumentation Services); Language Environment High Register Resolution ...

## *Supporting New Applications and New Workloads*

The zBX can support the IBM Smart Analytics Optimizer for DB2 for z/OS, V1.1 (5697-AQT), The IBM WebSphere DataPower Integration Appliance XI50 for zEnterprise (DataPower XI50z), and select POWER7 and IBM System x blades ...

## *Extending the Network*

Intranode Management Network (INMN) – OSM CHPID's, **HiperSockets integration with IEDN (SoD<sup>2</sup>); ...**

## *Enhancing Security*

The following enhancements have been added to the Common Cryptographic Architecture support which is used in the Crypto Express3 feature when it is configured as a coprocessor: Expanded key support for AES algorithm; Enhanced ANSI TR-31 interoperable secure key exchange; ANSI X9.8 PIN security; PIN block decimalization table protection; Enhance CCA keys wrapping to comply with ANSI X9.24-1 key bundling requirements; Secure key HMAC (Keyed-Hash Message Authentication Code); PKA RSA OAEP with SHA-256 algorithm; Elliptical Curve Cryptography (ECC) Digital Signatures; CP Assist for Cryptographic Function (CPACF) enhancements; 64 Bit; CKDS Constraint Relief; PCI Audit; CBC Key Wrap; and RMF Postprocessor Crypto Activity report support for 4096-bit; **Changes to the Common Cryptographic Architecture, Crypto Express3, and Trusted Key Entry (Expanded support for AES algorithm, enhanced ANSI TR-31 Secure Key Exchange, PIN block decimalization table protection, PKA RSA OAEP with SHA-256 algorithm, and additional Elliptic Curve Cryptography (ECC) functions) ...**

<sup>6</sup><sub>1</sub> z196 only

<sup>2</sup> Planned. All statements regarding IBM's plans, directions, and intent are subject to change or withdrawal without notice.

## z196 Support by z/OS Release

- **z196 capabilities differ depending on z/OS release**
  - **Toleration support provided on z/OS V1.8 and z/OS V1.9**
    - The IBM Lifecycle Extension for z/OS is required on z/OS V1.8 and z/OS V1.9
  - **Exploitation support on z/OS V1.10 and higher**
    - The IBM Lifecycle Extension for z/OS will be required on z/OS V1.10 for support (after 9/30/2011)
- **Software requirements differ depending on z/OS release and functions exploited**
  - **Support provided via a combination of web deliverables and PTFs**
  - **z196 Required PTFs**
    - **Documented in z196 PSP Bucket: Upgrade = 2817DEVICE, Subset = 2817/ZOS**
      - Broken out by z/OS release, identifying required and exploitation
    - **Can be identified by SMP/E commands (REPORT MISSINGFIX, LIST, or APPLY)**
      - **Fix Categories:**
        - » **IBM.Device.Server.z196-2817**
        - » **IBM.Device.Server.z196-2817.ParallelSysplexInfiniBandCoupling**
        - » **IBM.Device.Server.z196-2817.ServerTimeProtocol**
        - » **IBM.Device.Server.z196-2817.zHighPerformanceFICON**
        - » **IBM.Device.Server.z196-2817.UnifiedResourceManager**
  - **zBX Required PTFs**
    - **Documented in z196 PSP Bucket: Upgrade = 2458DEVICE, Subset = 2458/ZOS**
      - Broken out by z/OS release, identifying required and exploitation
    - **Can be identified by SMP/E commands (REPORT MISSINGFIX, LIST, or APPLY)**
      - **Fix Categories**
        - » **IBM.Device.Server.zBX-2458**
        - » **IBM.Device.Server.zBX-2458.ISAOPT**

## z114 Support by z/OS Release

- **z114 capabilities differ depending on z/OS release**
  - **Toleration support provided on z/OS V1.8 and z/OS V1.9**
    - The IBM Lifecycle Extension for z/OS is required on z/OS V1.8 and z/OS V1.9 for support
  - **Exploitation support on z/OS V1.10 and higher**
    - The IBM Lifecycle Extension for z/OS will be required on z/OS V1.10 for support (after 9/30/2011)
- **Software requirements differ depending on z/OS release and functions exploited**
  - **Support provided via a combination of web deliverables and PTFs**
  - **z114 Required PTFs**
    - All PTFs in the z196 PSP Bucket are required PLUS
    - Documented in zNext BC PSP Bucket: Upgrade = 2818DEVICE, Subset = 2818/ZOS
      - Broken out by z/OS release, identifying required and exploitation
    - Can be identified by SMP/E commands (REPORT MISSINGFIX, LIST, or APPLY)
      - Fix Categories:
        - » IBM.Device.Server.z114-2818
        - » IBM.Device.Server.z114-2818.ParallelSysplexInfiniBandCoupling
        - » IBM.Device.Server.z114-2818.ServerTimeProtocol
        - » IBM.Device.Server.z114-2818.zHighPerformanceFICON
        - » IBM.Device.Server.z114-2818.UnifiedResourceManager
  - **zBX Required PTFs**
    - Same as z196 – use Upgrade = 2458DEVICE, Subset = 2458/ZOS
    - Can be identified by SMP/E commands (REPORT MISSINGFIX, LIST, or APPLY)
      - Fix Categories
        - » IBM.Device.Server.zBX-2458
        - » IBM.Device.Server.zBX-2458.ISAOPT



# z/OS Support Summary



Release	z900 WdfM	z800 WdfM	z990 WdfM	z890 WdfM	z9 EC WdfM	z9 BC WdfM	z10 EC	z10 BC	z196 CPC	z196 w/zBX	z114 CPC	z114 w/zBX	End of Service	Coexists with z/OS
z/OS V1.8	X	X	X	X	X	X	X	X	X		X		9/09 <sup>1</sup>	V1.10
z/OS V1.9	X	X	X	X	X	X	X	X	X		X		9/10 <sup>1,2</sup>	V1.11*
z/OS V1.10	X	X	X	X	X	X	X	X	X	X	X	X	9/11 <sup>1,3</sup>	V1.12*
z/OS V1.11	X	X	X	X	X	X	X	X	X	X	X	X	9/12*	V1.13*
z/OS V1.12	X	X	X	X	X	X	X	X	X	X	X	X	9/13*	V1.14*
z/OS V1.13	X	X	X	X	X	X	X	X	X	X	X	X	9/14*	V1.15*

**Notes:**

- 1 The IBM Lifecycle Extension for z/OS provides the ability for customers to purchase extended defect support for that release of z/OS for up to 24 months after the z/OS release's end of service date
- 2 The IBM Lifecycle Extension for z/OS V1.9 was required after 9/30/2010 for support
- 3 **The IBM Lifecycle Extension for z/OS V1.10 will be required after 9/30/2011 for support**
- \* Planned. All statements regarding IBM's plans, directions, and intent are subject to change or withdrawal without notice.

## Supported z/OS Releases and ICSF Levels

- **z/OS V1.8 Crypto customers can run with:**
  - HCR7731 – Base z/OS V1.8
  - HCR7750 – Cryptographic Support for z/OS V1R7-V1R9 and z/OS.e V1R7-V1R8
  - HCR7751 – Cryptographic Support for z/OS V1.8 through z/OS V1.10 and z/OS.e V1.8
- **z/OS V1.9 Crypto customers can run with:**
  - HCR7740 – Base z/OS V1.9
  - HCR7750 – Cryptographic Support for z/OS V1R7-V1R9 and z/OS.e V1R7-V1R8
  - HCR7751 – Cryptographic Support for z/OS V1.8 through z/OS V1.10 and z/OS.e V1.8
  - HCR7770 – Cryptographic Support for z/OS V1R9-V1R11
- **z/OS V1.10 Crypto customers can run with:**
  - HCR7750 – Base z/OS V1.10
  - HCR7751 – Cryptographic Support for z/OS V1.8 through z/OS V1.10 and z/OS.e V1.8
  - HCR7770 – Cryptographic Support for z/OS V1R9-V1R11
  - HCR7780 – Cryptographic Support for z/OS V1R10-V1R12
- **z/OS V1.11 Crypto customers can run with:**
  - HCR7751 – Base z/OS V1.11
  - HCR7770 – Cryptographic Support for z/OS V1R9-V1R11
  - HCR7780 – Cryptographic Support for z/OS V1R10-V1R12
  - HCR7790 – Cryptographic Support for z/OS V1R11-V1R13
- **z/OS V1.12 Crypto customers can run with:**
  - HCR7770 – Base z/OS V1.12
  - HCR7780 – Cryptographic Support for z/OS V1R10-V1R12
  - HCR7790 – Cryptographic Support for z/OS V1R11-V1R13
- **z/OS V1.13 Crypto customers can run with:**
  - HCR7780 – Base z/OS V1.13
  - HCR7790 – Cryptographic Support for z/OS V1R11-V1R13

## z/OS Toleration Software Support for zEnterprise

- **Provides same functionality as that on the IBM System z10**
  - HiperDispatch, OSA-Express3, FICON Express8, Parallel Sysplex InfiniBand (PSIFB) Coupling Links, CF Level 16, High Performance FICON, CPU Measurement Facility, Hardware Decimal Floating Point
  - (z/OS V1.9) Greater than 54 CPs for a single LPAR, Large Page Support, Capacity Provisioning, HiperSockets Multiple Write Facility, OSA-Express3 Double Port Density, STP Enhancements
  - Crypto Toleration (CP Assist for Cryptographic Functions and Configurable Crypto Express2, Key management for remote loading of ATM and Point of Sale (POS) keys,...)
    - Toleration requires a Cryptographic Web deliverable to be installed
  - Crypto Exploitation (Crypto Advanced Encryption Standard (AES) for 256-bit keys SHA-384 and 512 bit for message digest support, RSA keys up to 4096 bits in Length, Support for 13-digit through 19-digit PANs data, Secure Key AES Support, ...)
    - Exploitation varies depending on Cryptographic Web deliverable installed
- **Plus for z/OS V1.8 and z/OS V1.9**
  - OSA-Express3 (GbE LX and SX, 1000BASE-T, 10 GbE LR and SR)
  - FICON Express8
  - **PCIe-based I/O Infrastructure – FICON Express8S and OSA Express4S**
  - New z/Architecture Instructions (and new OPCODE support)
  - InfiniBand Coupling Links
  - HiperDispatch cache and affinity node changes
  - IFAURP Reporting
  - Toleration for >64 CPs on the server
  - OSA-Express3 (CHPID Type OSD) with or without exploitation of two ports per CHPID
  - Crypto toleration



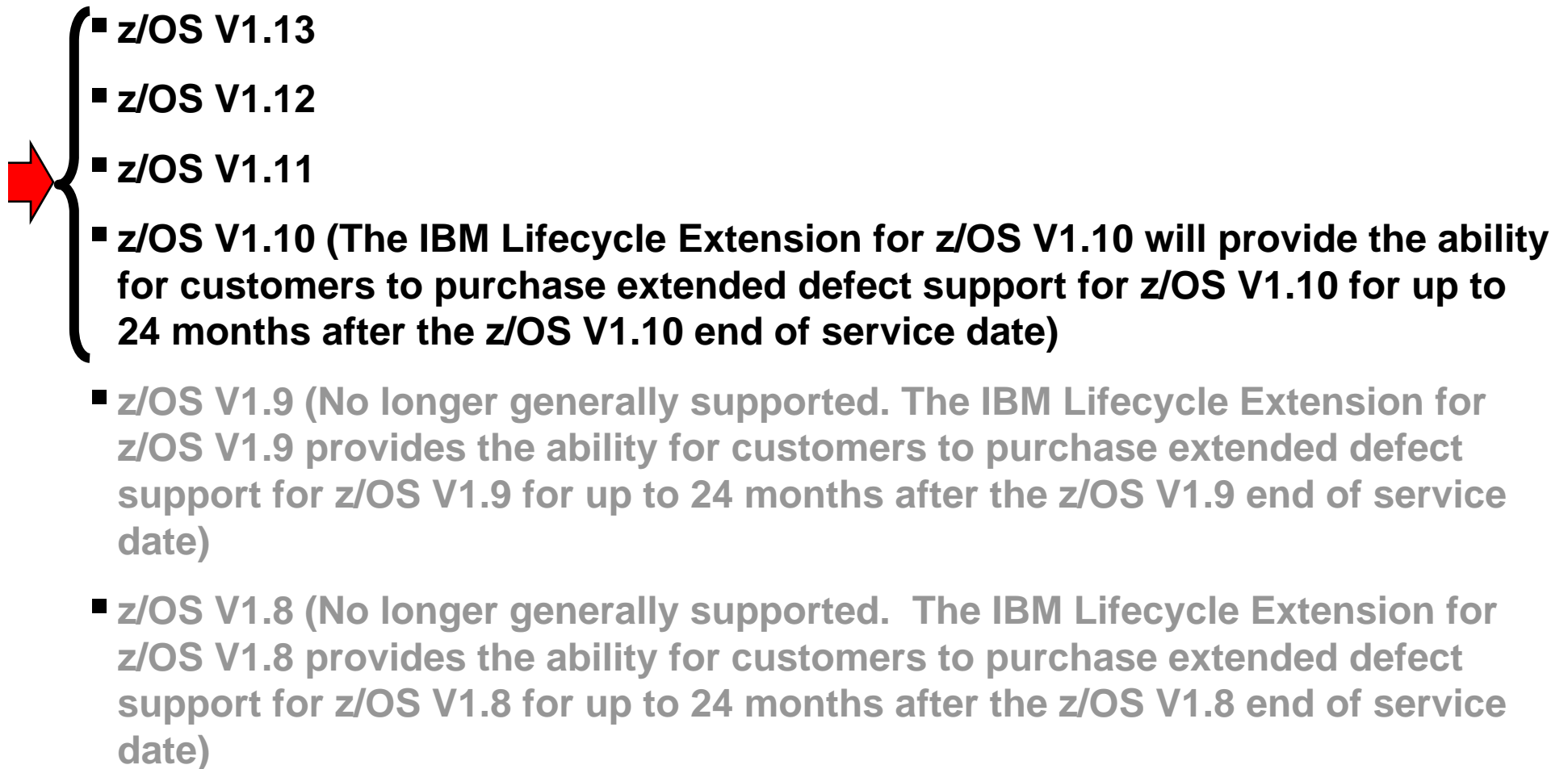

## z/OS Supported Software Environments for zEnterprise

- 
- z/OS V1.13
  - z/OS V1.12
  - z/OS V1.11
  - **z/OS V1.10 (The IBM Lifecycle Extension for z/OS V1.10 will provide the ability for customers to purchase extended defect support for z/OS V1.10 for up to 24 months after the z/OS V1.10 end of service date)**
  - z/OS V1.9 (No longer generally supported. The IBM Lifecycle Extension for z/OS V1.9 provides the ability for customers to purchase extended defect support for z/OS V1.9 for up to 24 months after the z/OS V1.9 end of service date)
  - z/OS V1.8 (No longer generally supported. The IBM Lifecycle Extension for z/OS V1.8 provides the ability for customers to purchase extended defect support for z/OS V1.8 for up to 24 months after the z/OS V1.8 end of service date)

## z/OS Software Positioning for a zEnterprise (z196 or z114) Server

### z/OS Exploitation Support for IBM zEnterprise (z196 or z114)

- All functions listed for z/OS V1.8 and z/OS V1.9
- **z/OS V1.10 and higher**
  - zBX support for the IBM Smart Analytics Optimizer for DB2 for z/OS, V1.1 (5697-AQT), the IBM WebSphere DataPower Integration Appliance XI50 for zEnterprise (DataPower XI50z), and select POWER7 and IBM System x blades
  - IBM zEnterprise Unified Resource Manager
    - Network and Performance Management
    - Intranode Management Network (INMN) and Intraensemble data network (IEDN)
  - HiperDispatch performance and serviceability enhancements
  - Static Power Save Mode (z196 only)
  - Language Environment High Register Resolution
  - CPU Measurement Facility (Hardware Instrumentation Services)
  - CF Level 17
  - Removal of the 64k byte data transfer limit for zHPF multitrack operations
  - Greater than 64 CPs per LPAR
  - Up to 32 HiperSockets
  - Three subchannel sets
  - Crypto Exploitation (ANSI X9.8 Pin security, enhanced Common Cryptographic Architecture (CCA), 64 Bit, CP Assist for Cryptographic Function (CPACF) enhancements, Secure Keyed-Hash Message Authentication Code (HMAC), CKDS Constraint Relief, PCI Audit, Elliptical Curve Cryptography (ECC) Digital Signature Algorithm, CBC Key Wrap, and **PKA RSA OAEP with SHA-256 algorithm**)
  - RMF Postprocessor Crypto Activity report support for 4096-bit
- **z/OS V1.11 and higher**
  - **IPL for alternate subchannel set**
  - **zHPF Performance improvements for FICON Express 8S**
  - **Crypto Exploitation**
    - **z/OS V1.11-z/OS V1.13: Expanded key support for AES algorithm, enhanced ANSI TR-31 Secure Key Exchange, PIN block decimalization table protection, PKA RSA OAEP with SHA-256 algorithm, and additional Elliptic Curve Cryptography (ECC) functions.**
- **z/OS V1.12 and higher**
  - XL C/C++ ARCH(9) and Tune(9) Options
  - zDAC support
  - New display command – D OSAINFO
  - **OSA-Express3 and OSA-Express4S** Inbound Workload queueing (IWQ)
  - Nondisruptive CF Dump
- **z/OS V1.13 only**
  - **OSA-Express4S checksum offload for IPv6**
  - **OSA-Express4S checksum offload for LPAR to LPAR traffic (both IPv4 and IPv6)**
  - **Large Send for IPv6**
  - **Inbound Workload queueing (IWQ) for Enterprise Extender traffic**
  - **HiperSockets optimization for intraensemble data networks (SoD)**





z/OS Software Positioning for a zEnterprise (z196 or z114) Server

# z/OS Exploitation Support for IBM zEnterprise (z196 or z114)

Release	z196 PSP Bucket – 2817DEVICE 2817/ZOS and z114 PSP Bucket – 2818DEVICE 2818/ZOS																																				
	Base Support														Exploitation Support																						
	Base z196 and z114 Support	OSA-Express3 (Gbe LX and SR, 1000BASE-T, 10 Gbe LR and SR)	FICON Express8 (CHPID FC)	PCIe-based I/O Infrastructure – FICON Express85 and OSA Express45	New z/Architecture Instructions3	IB Coupling Links	Up to 128 Coupling Link CHPIDs	HiperDispatch Cache/Affinity Changes	IFAURP Reporting	>64 CPs per Server5	Crypto Toleration4	OSA-Express3 CHPID OSD max ports	RMF Postprocessor Crypto Activity report - 4096-bit	CPU Measurement Facility (HIS)	> 64 CPs per LPAR5	Three Subchannel Sets5	HiperDispatch Serviceability	LE High Register Resolution	Up to 32 HyperSockets	Power Save Mode5	CF Level 17	Removal of 64K byte data transfer limit for zHPF multitrack operations	Crypto Exploitation6	IBM zEnterprise BladeCenter Extension (zBX) support	Unified Resource Manager (zManager)	IPL for alternate subchannel set	ZHPF Performance improvements for FICON Express 85	Nondisruptive CF Dump	zDAC Support	New OSA Display Command	OSA-Express3 Inbound Workload queueing (IWQ)	XL C/C++ ARCH(9) Tune(9)	IWQ for Enterprise Extender	OSA-Express45 checksum offload for IPv6 and LPAR to LPAR traffic	Large Send for IPv6	intra-ensemble data networks7	
z/OS V1.10 <sup>2</sup>	P	P	P	B	P	P	P	P	P	P	B	P	P	P	P	P	P	P	P	P	P	W	P	P	N	N	N	N	N	N	N	N	N	N	N	N	N
z/OS V1.11	P	P	P	B	P	P	P	P	P	B	P	P	P	B	P	P	P	P	P	P	P	W	P	P	P	N	N	N	N	N	N	N	N	N	N	N	N
z/OS V1.12	P	B	B	B	B	B	B	B	B	P	B	B	B	B	B	B	B	B	B	B	B	W	B	B	P	P	B	B	B	B	B	B	N	N	N	N	N
z/OS V1.13	P	B	B	B	B	B	B	B	B	B	B	B	B	B	B	B	B	B	B	B	B	W	B	B	P	P	B	B	B	B	B	B	B	B	B	B	B

- 1 – The Lifecycle Extension for z/OS V1.8 or z/OS V1.9 is required for support
- 2 - The IBM Lifecycle Extension for z/OS V1.10 will be required after 9/30/2011 for support
- 3 – Does not include XL C/C++ support for ARCH(9) and TUNE(9) Options
- 4 – A Crypto Web Deliverable is NOT required, but toleration PTF is needed even if a web deliverable is installed. Support differs depending on the Crypto Web Deliverable installed
- 5 – Function available on z196 only
- 6 – Crypto Exploitation differs based on the Crypto Web Deliverable installed
- 7 – Statement of Direction. All statements regarding IBM's plans, directions, and intent are subject to change or withdrawal without notice.

B – FMID in Base product

W – FMIDs shipped in a Web Deliverable

P – PTFs are required, P1 – Support differs by release

P2- PTF required for toleration, N – Not Supported



# Migration Considerations



## Hardware Migration Considerations

- The following features are not orderable on the System z196 models. If they are installed at the time of an upgrade to the System z196, they may be retained.
  - FICON Express4 10KM LX
  - FICON Express4 SX
  - FICON Express4 4KM LX
  - FICON Express4-2C 4KM LX
  - FICON Express4-2C SX
  - OSA-Express2 GbE LX
  - OSA-Express2 GbE SX
  - OSA-Express2 1000BASET
  
- The following will NOT be supported on System z196 nor z114:
  - FICON Express
  - FICON Express2
  - Crypto Express2
  - OSA-Express2 10 GbE LR

## z196 General Migration Considerations

### ■ Software Changes

- z/OS releases do not require z196 or z114 servers
- z196 and z114 servers ONLY require software identified as ‘base’ support
  - Minimal toleration support needed depending on z/OS release (e.g., ICSF toleration)
  - z196 and z114 servers do NOT require any ‘functional’ software
- Very few new migration issues identified (next chart)
  - z990, z890, z9 EC, z9 BC, z10 EC, and z10 BC migration actions “inherited”
  - “Inherited” and new sysplex considerations
  - Many functions are enabled/disabled based on the presence or absence of the required hardware and software.
    - Some functions have exploitation or migration considerations (subsequent charts)

## z196 or z114 Specific Migration Considerations

- **New z196/z114 z/Architecture Machine Instructions**
  - New mnemonics
  - Use of XL C/C++ ARCH(9) and TUNE(9) options
- **Sysplex Considerations**
  - Server participation restriction in a Parallel Sysplex
  - Evaluate Coupling Links requirements
    - z196 and z114 do not support ICB-4 Coupling Links
  - Evaluate Sysplex Timer environment
    - z196 and z114 do not support connection to an ETR
      - A mixed CTN configuration IS supported
        - » z10 and z9 servers using ETR or STP, z196 or z114 servers using STP
  - New CFCC Level
    - Evaluate structure sizes
    - Increased CFCC footprint
- **Update SCRT to latest version**
  - Always required if you want to use vWLC

## New z/Architecture Machine Instructions

- **The new mnemonics may collide with (be identical to) the names of Assembler macro instructions you use**
  - **If you write programs in Assembler Language, you should compare the list of new instructions to the names of Assembler macro instructions you use and/or provide**
  - **If a conflict is identified, take one of these actions:**
    - **Change the name of your macro instruction.**
    - **Specify a separate assembler opcode table**
      - **via PARM= , ASMAOPT, or ‘\*PROCESS OPTABLE....’ in source**
    - **Use a coding technique that permits both use of a new instruction and a macro with the same name in an assembly**
- **Use of XL C/C++ ARCH(9) and TUNE(9) options**
  - **See later chart**

## z/OS XL C/C++ Exploitation of z196/z114 Machine Instructions

### ■ C/C++ ARCH(9) and TUNE(9) options:

- The ARCHITECTURE C/C++ compiler option selects the minimum level of machine architecture on which your program will run.
  - ARCH(9) exploits instructions available on a z196 or z114 server
  - The TUNE compiler option allows you to optimize your application for a specific machine architecture within the constraints imposed by the ARCHITECTURE option
    - The TUNE level has to be at least the ARCH level
    - If the TUNE level is lower than the specified ARCH level, the compiler forces TUNE to match the ARCH level or uses the default TUNE level, whichever is greater.
    - For more information on the ARCHITECTURE and TUNE compiler options refer to the z/OS XL C/C++ User's Guide.

### ■ Exploitation Restriction:

- Code compiled with the C/C++ ARCH(9) option can only run on z196 or z114 servers, otherwise an operation exception will result
- This is a consideration for programs running on different level servers during development, test, production, and during fallback or DR

## Server Participation in a Parallel Sysplex

- **z196 and z114 do not support active participation in the same Parallel Sysplex with:**

- IBM eServer zSeries 900 (z900), IBM eServer zSeries 800 (z800),
- IBM eServer zSeries 990 (z990), IBM eServer zSeries 890 (z890),
- and older System/390 Parallel Enterprise Server systems

**This means:**

- Configurations with z/OS on one of these servers can't add a z196 or z114 server to their sysplex for either a z/OS image or a CF image
- Configurations with a CF on one of these servers can't add a z196 or z114 server to their sysplex for either a z/OS image or a CF image

- **z196 and z114 do not support ICB-4 Coupling Links**

- Customers should plan their coupling link technology

- **z196 and z114 do not support connection to an ETR**

- Customers should migrate to STP prior to z196 or z114 server

## z196 – Parallel Sysplex Coexistence Considerations

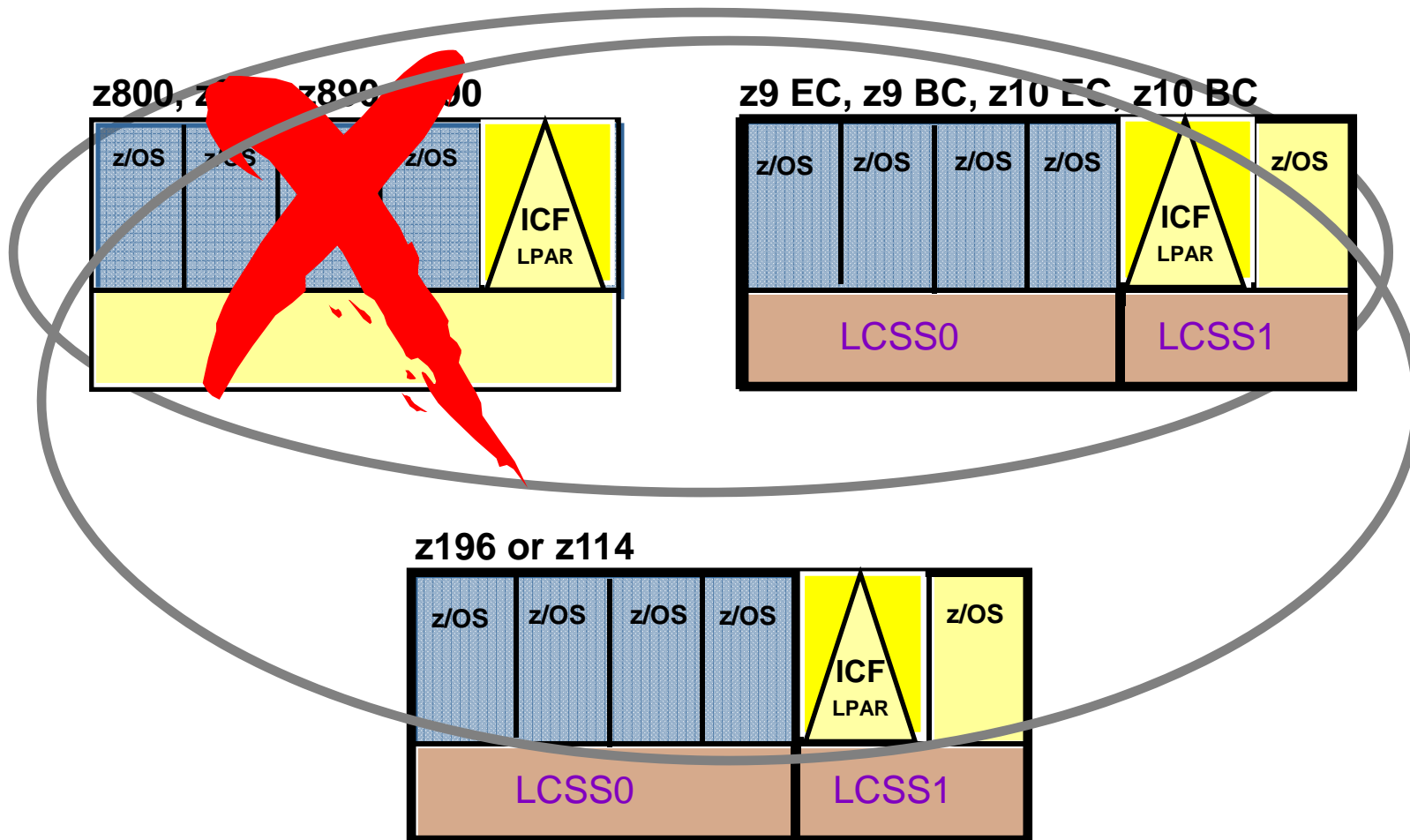

# z196 Parallel Sysplex coexistence of Servers/CFs and coupling connectivity

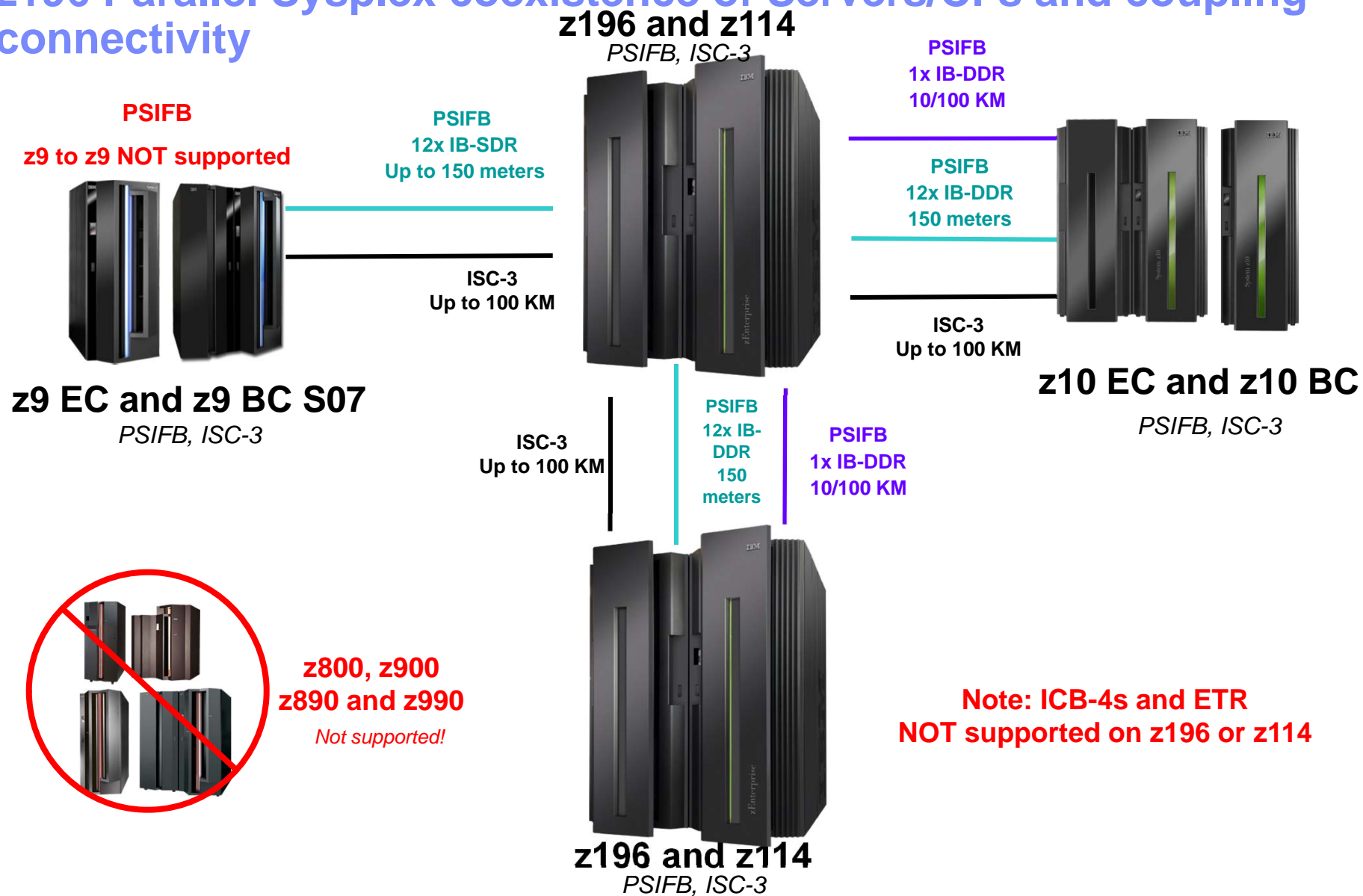



## Parallel Sysplex (No ICB-4 Link Support)

The "intermediate" CFs can provide a 'bridge' to connect to z196 or z114

- No ICB-4 Links to z196 or z114
- Can intermix existing ICB4 and PSIFB link technology if using z9 or z10 Coupling Facilities

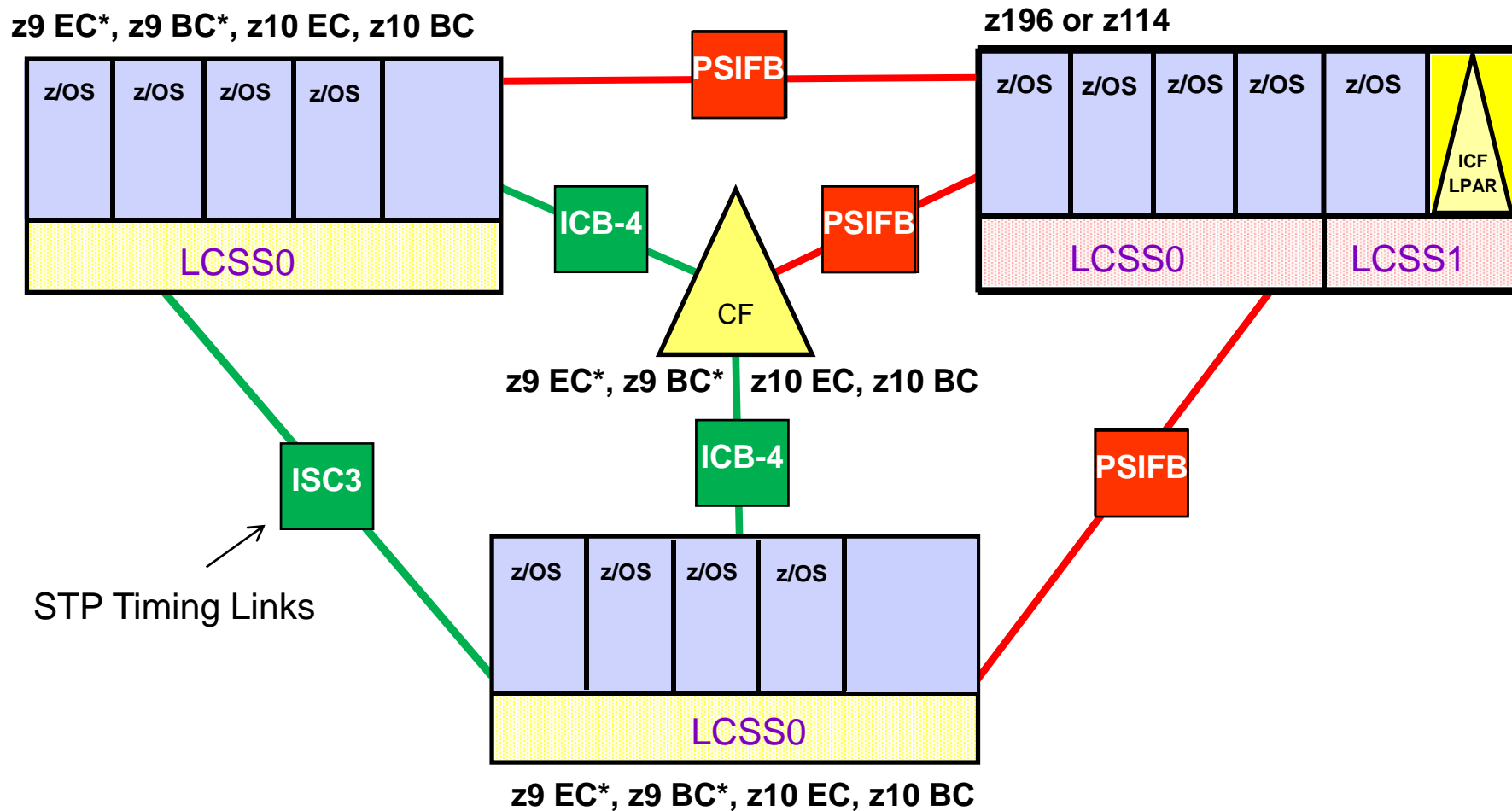

\* Note: PSIFB links are NOT available for ordering from IBM marketing on System z9 servers after June 30, 2010

## STP Configurations

- Two types of Coordinated Timing Network (CTN) configurations possible:
  - Mixed CTN
    - Allows servers/CFs that can only be synchronized to a Sysplex Timer (ETR network) to coexist with servers/CFs that can be synchronized with CST in the “same” timing network
    - Sysplex Timer provides timekeeping information
    - CTN ID format
      - STP network ID concatenated with ETR network ID
  - STP-only CTN
    - All servers/CFs synchronized with CST
    - Sysplex Timer is NOT required
    - CTN ID format
      - STP network ID only (ETR network ID field has to be null)

# Mixed CTN Example with System z196 server

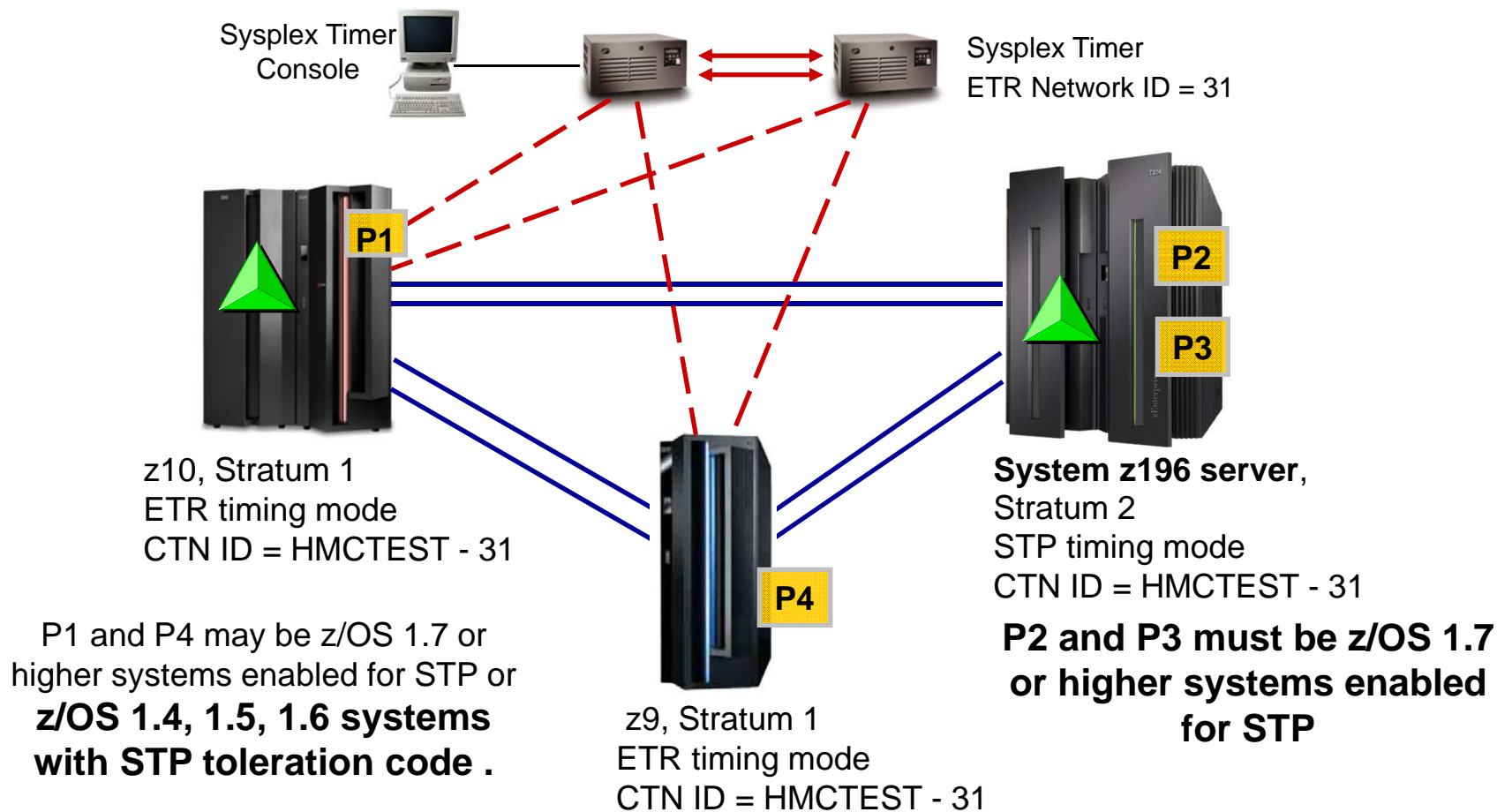

**Strong recommendation:** Configure at least two Stratum 1 servers before configuring a z196 server as S2 – to avoid a single point of failure

# STP-only CTN Example with System z196 server

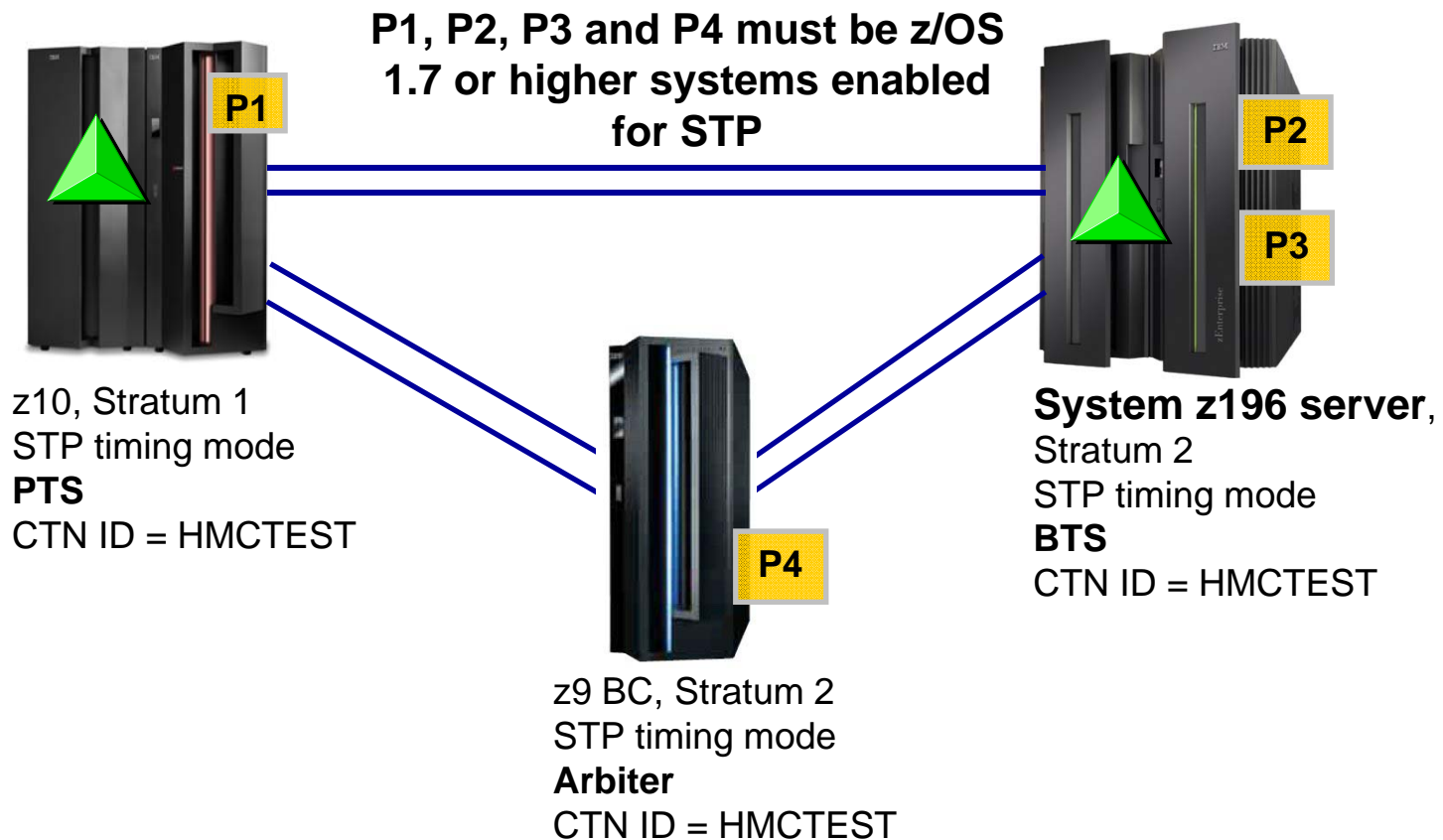

## System z CFCC Level 17

- **CFCC Level 17 allows:**
  - Up to 2047 CF structures (CFCC 16 allowed 1023).  
Allowing more CF structures to be defined and used in a sysplex permits more discrete data sharing groups to operate concurrently, and can help environments requiring many structures to be defined, such as to support SAP or service providers
  - Nondisruptive CF dump
  - Improved CFCC Diagnostics & Link Diagnostics
- **Structure and CF Storage Sizing with CFCC level 17**
  - May increase storage requirements when moving from:
    - CF Level 16 (or below) to CF Level 17
  - CF Sizer Tool recommended
    - <http://www.ibm.com/systems/z/cfsizer/>
- **Increased CFCC footprint**
  - The CFCC footprint has increased, ensure that you have at least 512MB for CFCC in any CFCC Level 17 LPAR
- **Greater than 1023 CF Structures requires a new version of the CFRM CDS**
  - All systems in the sysplex need to be at z/OS V1.12 (or later) or have the coexistence/preconditioning PTF installed.
  - Falling back to a previous level (without coexistence PTF installed) is NOT supported without sysplex IPL

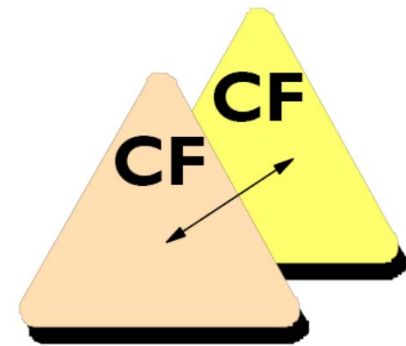

## Customization / Activation (Power Save Mode)

### ■ The new SMFPRMxx PARMLIB option

#### **MAXEVENTINTRECS**

- Allows governing the number of event interval records to be collected when the processor capacity changes.
- The default is zero
- To collect extra records between regular intervals when the processor capacity changes, the default must be adjusted.

### ■ CPU Measurement Facility (HIS)

- A new parameter to the MODIFY HIS command is necessary to override the default action to take when a CPU speed change is detected within the HIS component
- Parameter: { STATECHANGE | SC } = {SAVE | STOP | IGNORE}

## Customization / Activation for Cache and Affinity Node Changes

- **z196 and z114 uses chip level cache more efficiently**
  - Allows 3 physical CPs from same chip to form affinity node
    - *Note: A z10 uses HiperDispatch book cache support and 4 physical CPs from same book*
- **z/OS now forces HiperDispatch=YES for LPARs with >64 CPs**
  - On LPARs with >64 CPUs defined on z196 with IEAOPTxx specifying HIPERDISPATCH=NO during IPL / SET OPT=xx after IPL:
    - System forced / continues running with HIPERDISPATCH=YES
    - New Message:
      - IRA865I HIPERDISPATCH=YES FORCED DUE TO GREATER THAN 64 LPS DEFINED
  - LPARs in HD=NO with <64 CPUs can dynamically add more CPUs and continue to run in HD=NO. Results in the following:
    - New Message:
      - ISN012E HIPERDISPATCH MUST BE ENABLED TO CONFIGURE CPU IDS GREATER THAN 3F ONLINE
    - Attempts to configure CPUs >64 online in HD=NO rejected with message:
      - IEE241I CPU(x) NOT RECONFIGURED ONLINE - REQUIRES HIPERDISPATCH ENABLED
    - Once an LPAR with >64 CPUs goes to HD=YES, it cannot go back to HD=NO
      - Treated as if IPLed with HD=YES once HD=YES activated
- **Note: z/OS V1.13 defaults to HIPERDISPATCH=YES**

## Customization / Activation for Cache and Affinity Node Changes

- **On z196, SUP\_HiperDispatchCPUConfig Health Check added**
  - Always succeeds for LPAR in HD=YES (all CPU configurations supported)
  - When LPAR in HD=NO, raises an exception when # of CPUs is “close” to forcing the LPAR to IPL with HD=YES.
    - CPUSLEFTB4NEEDHD (default 8, 0-63 accepted) parameter indicates the minimum number of CPUs that can be installed and activated on an LPAR running in HD=NO.
      - When CPUSLEFTB4NEEDHD=0, the check always succeeds.
  - System redrives check when HD state changes or CPU(s) dynamically added
  
- **Healthchecker Messages:**
  - IEAVEH080I CPU configuration supported with HiperDispatch *curstate*
  - IEAVEH081E CPU configuration supported with HiperDispatch disabled. *numcpus* more CPU(s) can be added with HiperDispatch disabled.



## Customization / Activation for HiperDispatch Serviceability

- **Provides HiperDispatch knobs, SIGP data, and suspend lock data needed to debug performance problems**
  - **z/OS Version 1 Release 11**
    - System suspend lock instrumentation data collection
    - Count SIGPs contributing to LPAR overheads data collection
  - **z/OS Version 1 Release 12**
    - System latch contention instrumentation data collection
    - Data collection for RMF for WEB Queue Distribution
  
- **There are no actions required to enable most of the functions**
  - Data is always collected
  - RMF can be configured to report some of the data

## Customization / Activation for Crypto Exploitation

- **Crypto Exploitation (software installation)**
  - **New ICSF web deliverable required for support**
    - Cryptographic Support for z/OS V1R11-V1R13 Web deliverable (HCR7790)
      - o Planned to become available September 10, 2011
      - o **NOT** integrated in ServerPac (even for z/OS V1.13)
      - o Only required to exploit new z196 or z114 function
      - o To exploit secure keyed HMAC – CKDS must be a variable length VSAM data set
        - » All images sharing this CKDS must be at HCR7780 or higher
      - o ICSF pubs will be updated with HCR7790 function
        - » Available online: <http://www.ibm.com/systems/z/os/zos/bkserv>
    - z/OS PTFs needed for some z10 GA3 and z196 (or z114) functions
    - New ICSF toleration PTFs needed when sharing keys in a sysplex
      - ECC Master Key (in PKDS)
      - CBC Key Wrap Support (in CKDS)
      - New SMP/E Fix Category will be created for ICSF coexistence
        - o IBM.Coexistence.ICSF.z/OS\_V1R11-V1R13-HCR7790
    - TKE 7.0 (or higher) is required for X9.8 PIN processing to enable access control points
    - **Old ICSF web deliverable was initially required for support**
      - Cryptographic Support for z/OS V1R10-V1R12 Web deliverable (HCR7780)
        - o Became available September 1, 2010
        - o **NOT** integrated in ServerPac z/OS V1.12 (but **IS** integrated in z/OS V1.13 ServerPacs)

## zEnterprise (z196 or z114) Crypto Express3 – UDX

### ▪ UDX (User Defined eXtension)

- Extends the functionality of IBM's CCA (Common Cryptographic Architecture) application program
  - Customized cryptographic verb controls per customer
- UDX interfaces using HW control blocks and ICSF CB, therefore if hw platform changes or ICSF level changes or both, then UDX must updated for the new control blocks
  - If a customer has UDX, they would already know this

## Customization / Activation for I/O Exploitation

### ■ Three Subchannel Sets

- Extension of Alternate Subchannel Set supports introduced in z/OS 1.7 and 1.10
- Same restrictions and considerations
  - PPRC-pair secondaries must either all be in subchannel set 1 or all be in subchannel set 2.
    - o Reminder: A PPRC-pair are where the primary is in one subchannel set and the secondary is in another subchannel set with the same device number
  - Aliases can appear in the same subchannel set as the PPRC-pair secondary devices.
  - Aliases can appear in all subchannel sets (0, 1, and 2).
  - Only PAV-alias (3390A), PPRC Secondary (3390D) or SAN back-up (3390S) devices
  - After a HyperSwap, Special PPRC pair of 3390B and 3390D must be added, deleted or changed together during a Dynamic Activate
- IODF statement of LOADxx
  - Allows the installation to select the subchannel set from which to bring primary PPRC devices online
    - o SCHSET parameter now allows values '0', '1' or '2'
    - o Can also be specified via operator prompt during IPL

## Customization / Activation for I/O Exploitation

- **z/OS FICON Discovery and AutoConfiguration (zDAC)**
  - zDAC is invoked through HCD and HCM
  - Provides automatic discovery for FICON DASD and TAPE control units
  - Reduces level of IT skill and time required to configure new I/O devices
  - Ensures system (host) and control unit definitions are compatible with each other
  
- **zDAC can**
  - Display a list of discovered FICON DASD and TAPE controllers
    - Indicates whether the controller is new (ie., no existing devices/control units defined on the controller in the target IODF)
  - Discover new devices for existing logical control units on a controller
  - Discover new devices and new logical control units on a controller, and propose new paths for each new logical control unit found
    - New devices and control units are displayed for either inclusion or exclusion in the target IODF
  
- **Through HCD or HCM, the user establishes a policy for the discovery operation**
  - Can limit the scope of the discovery
  - Can limit the proposal information
  - Can indicate the desired number of paths to discovered logical control units
  - Can indicate the method used for device and control unit numbering

## Customization / Activation for I/O Exploitation

- **z/OS FICON Discovery and AutoConfiguration (zDAC)**
  - zDAC is defined using the HCD Panels.
  - In order to run zDAC, each TSO userid has to have a HCD Profile set up.
  - The HCD profile is accessed HCD Profile Options and Policies (Option 0)
    - The Autoconfiguration Policy is Option 0,2 (next chart)
    - To add or edit Autoconfiguration Logical Partition Groups is Option 0,3
      - The LPARs specified in the LP Group can span z196 or z114 CECs
      - **All members of the group must be running z/OS V1.12 (or higher) or else the function will not work.**
    - To add or edit Autoconfiguration Operating System Groups is Option 0,4
      - Multiple OS's can be targeted for zDAC discovery.

# z/OS Discovery and AutoConfiguration Policy

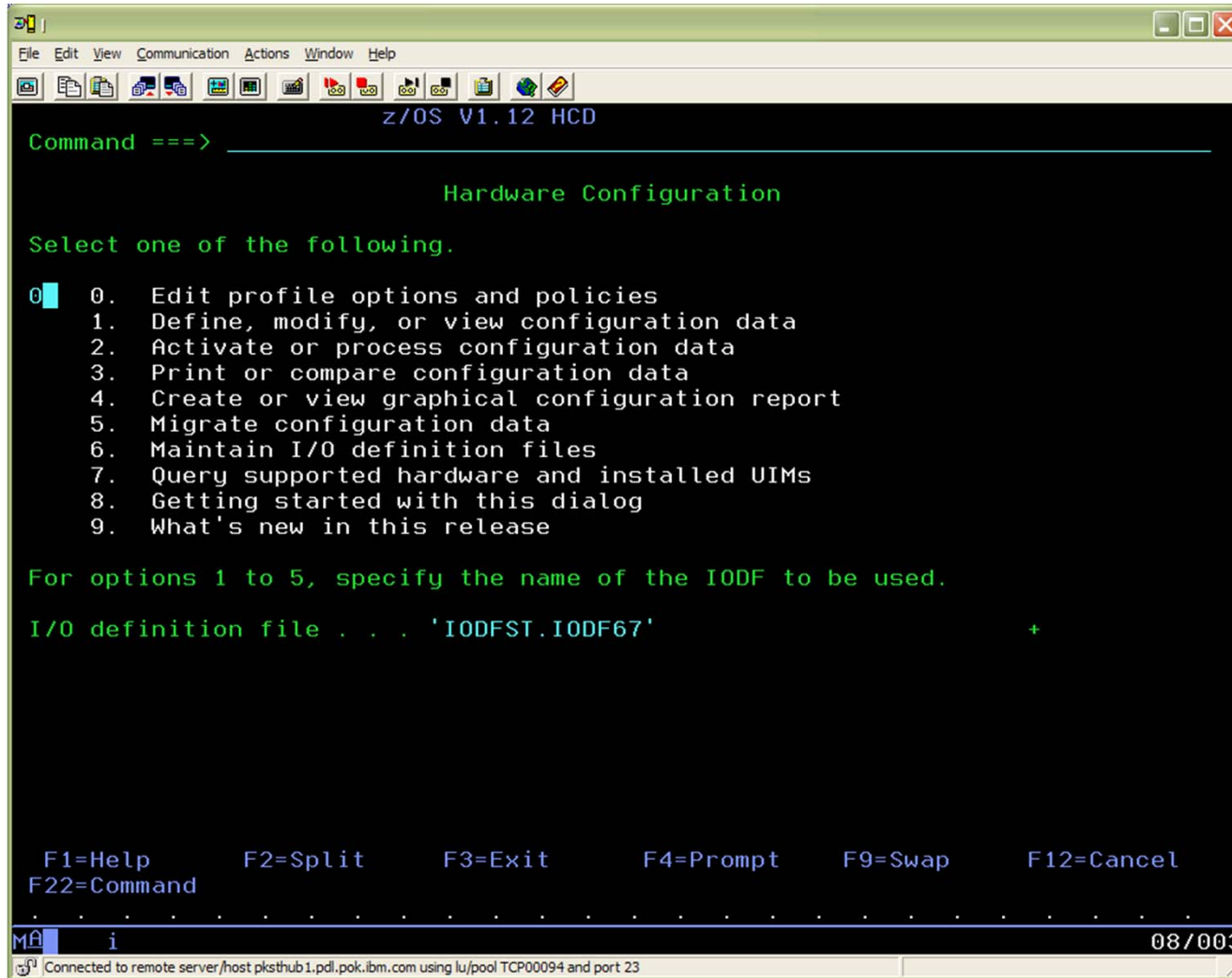

# z/OS Discovery and AutoConfiguration Policy

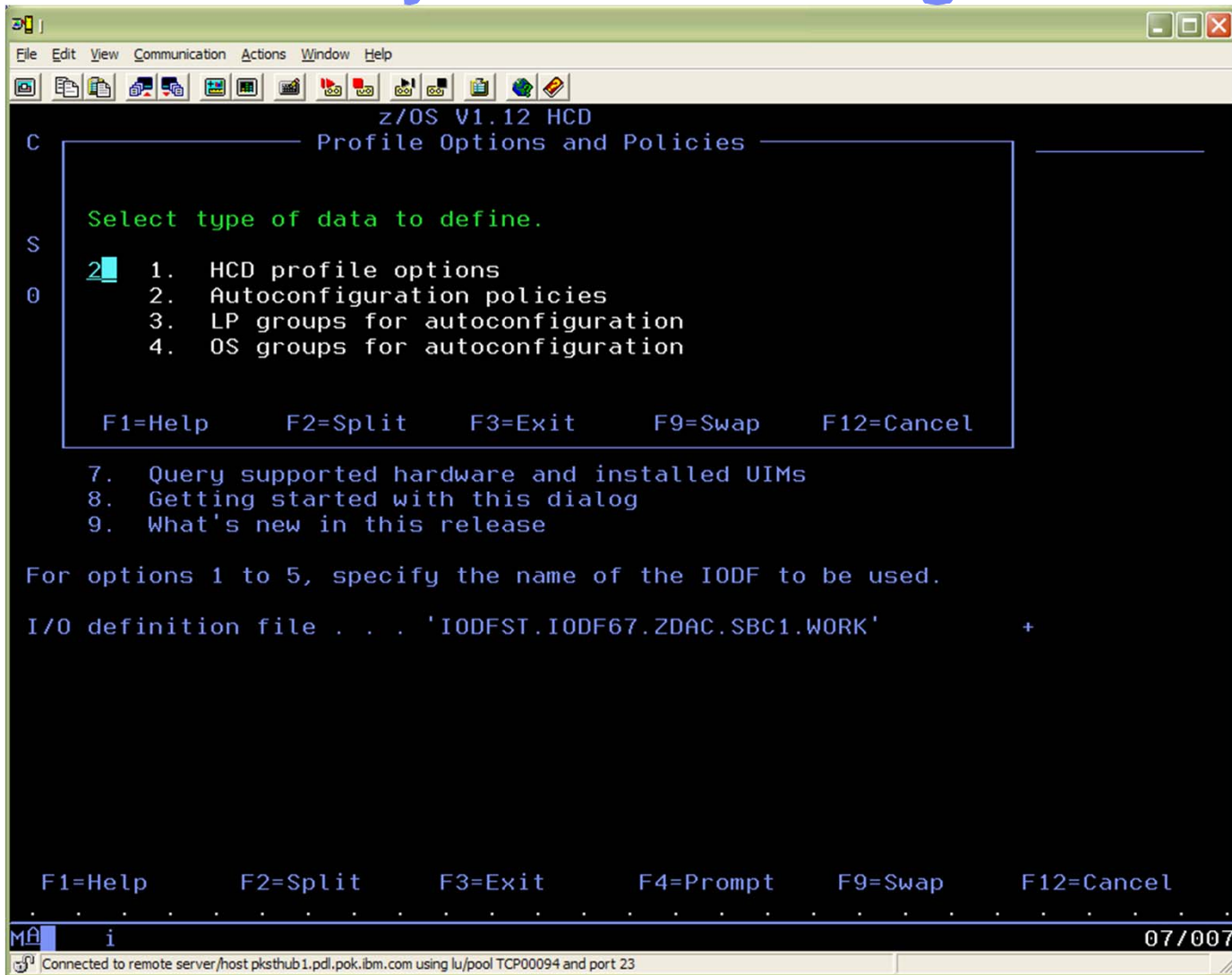



Specifies whether for autoconfiguration definitions a control unit number should match the base device number.

- If you specify Yes (which is the default), the first base device is set to the same number as the control unit.
- If No is specified, the device number of the first base device and the control unit number do not necessarily need to match.

Specifies the ID of the subchannel set in which

Defines the schema for assigning device numbers to PAV alias devices in an alternate subchannel set. Supported schemas are:

- CONSECUTIVE - The alias device numbers in an alternate subchannel set are consecutive to the base device numbers

Specifies the range of control unit numbers from which numbers for auto-defined control units will be taken. If no value is specified, range 0001-FFFE is taken as default. FFFE is the highest supported

Specifies the range of device numbers from which device numbers for auto-defined devices will be taken. If no value is specified, range 0001-FFFF is

Specifies the number of dynamically managed channel paths allowed on a control unit definition, if it is auto-defined. A maximum number of 7 channel paths is allowed. The default is 6.

Specifies the the name of a group of logical partitions

Specifies the name of a group of OS configurations to which auto-defined devices will be assigned. If no name is set, devices will be assigned to all OS configurations which correspond to the active LP group.

When pressing F4=Prompt a selection of all OS configuration groups defined in the currently accessed IODF is displayed.

### HCD Profile :

Policy keyword	Value
AUTO_MATCH_CU_DEVNUM	YES
AUTO_SS_ALTERNATE	1
AUTO_SS_DEVNUM_SCHEME	PAIRING
AUTO_SUG_CU_RANGE	0001-FFFE
AUTO_SUG_DEV_RANGE	0001-FFFF
AUTO_SUG_DYN_CHPID	6
AUTO_SUG_LPGROUP	
AUTO_SUG_OSGROUP	
AUTO_SUG_STAT_CHPID	
*****	*****

Specifies the number of static channel paths to be assigned to a control unit definition, if it is auto-defined. At least one and not more than 8 static channel paths should be defined. The default is 2.

# zDAC – HCD Add AutoConfiguration LP Group

```
Autoconfiguration LP Group List
C
C Add Autoconfiguration LP Group
T
S t Specify name and description for new LP group.
O / LP group name . . . . .
* Description . . . . .

F1=Help      F2=Split      F3=Exit      F5=Reset      F9=Swap
F12=Cancel

F
I  F1=Help      F2=Split      F3=Exit      F4=Prompt
   F7=Backward  F8=Forward    F9=Swap      F11=Add
   F12=Cancel
```

# zDAC – HCD Add AutoConfiguration OS Group

```
Autoconfiguration OS Group List
C
C      Add Autoconfiguration OS Group
T
S      Specify name and description for new OS group.
g
O      OS group name . . . . .
/*     Description . . . . .

F1=Help      F2=Split      F3=Exit      F5=Reset      F9=Swap
F12=Cancel

F
I      F1=Help      F2=Split      F3=Exit      F4=Prompt
       F7=Backward  F8=Forward   F9=Swap      F11=Add
       F12=Cancel
```

## Customization / Activation for I/O Exploitation

### zDAC

- zDAC discovery process is invoked via HCD panel Options 1,6.
- There are two phases of zDAC discovery:
  1. Fabric Discovery Phase
    - ▶ This phase interrogates the switches (Mdata, Brocade and CISCO) and discovers all of the TAPE and DASD Nodes that are logged in to the fabric.
    - ▶ Once this step is executed, a list of nodes is presented for the next phase of discovery.
  2. Controller Discovery Phase
    - ▶ This phase interrogates the Node, Tape or DASD, when selected for discovery. It determines CU and Device numbering based on the CU configuration, and the paths to be used for access.
    - ▶ A proposal will be presented and when accepted, the IODF workfile will contain the entries for the newly discovered node(s).
- Nodes that are discovered during the Fabric Discovery Phase are characterized as either NEW=YES or NEW=NO.
  - NEW=YES means that none of the devices on that Node have been defined in the IODF used for Discovery.
  - NEW=NO means that one or more devices on that Node are currently defined in the IODF used for discovery.

# z/OS Discovery and AutoConfiguration Request

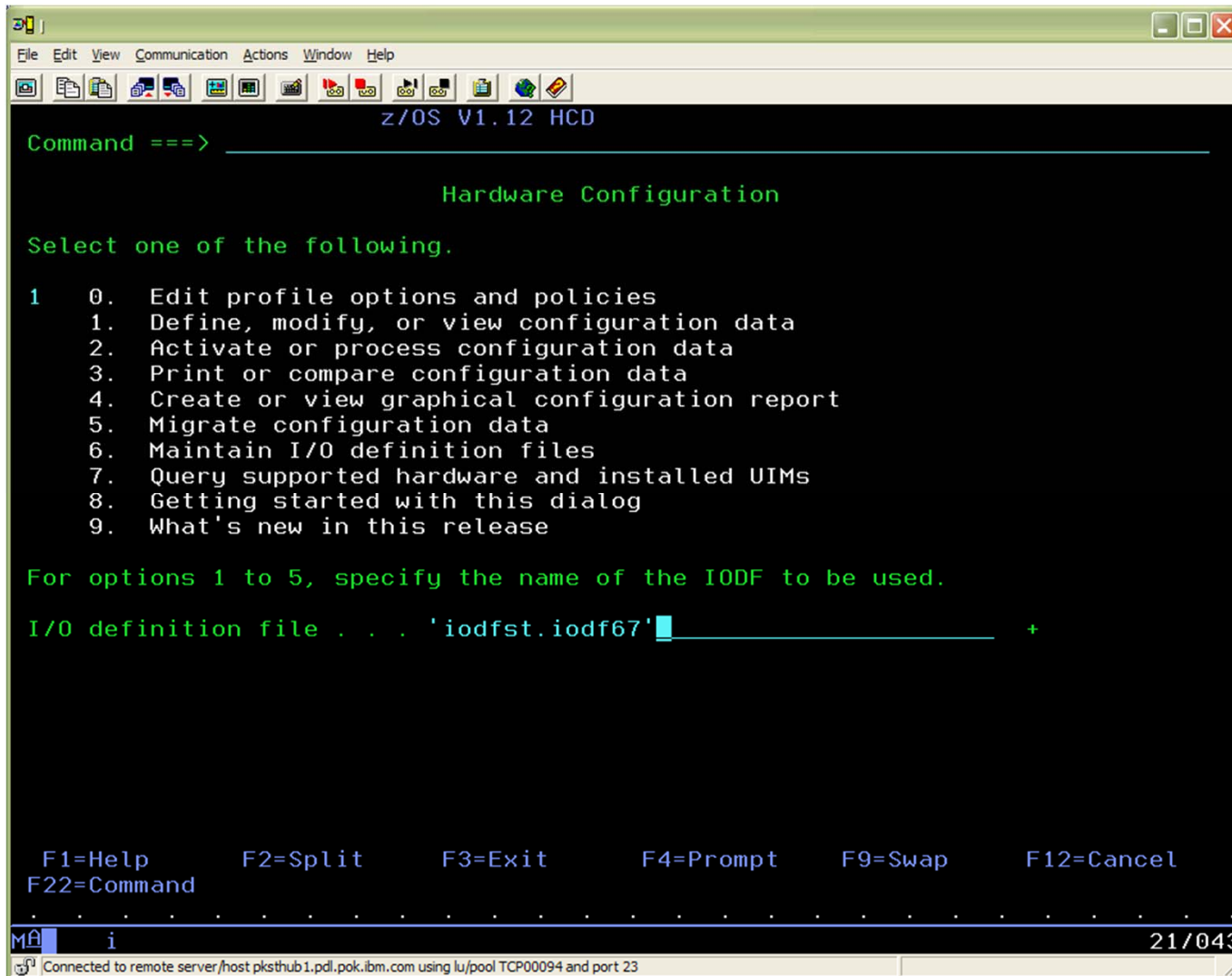

# zDAC – Discovery Process

```
z/OS V1.12 HCD
C Define, Modify, or View Configuration Data
  Select type of objects to define, modify, or view data.
  6_ 1. Operating system configurations
      consoles
      system-defined generics
      EDTs
      esoterics
      user-modified generics
  2. Switches
      ports
      switch configurations
      port matrix
  3. Processors
      channel subsystems
      partitions
      channel paths
  4. Control units
  5. I/O devices
  6. Discovered new and changed control units and I/O devices
F1=Help  F2=Split  F3=Exit  F9=Swap  F12=Cancel
```

# z/OS Discovery and AutoConfiguration Request

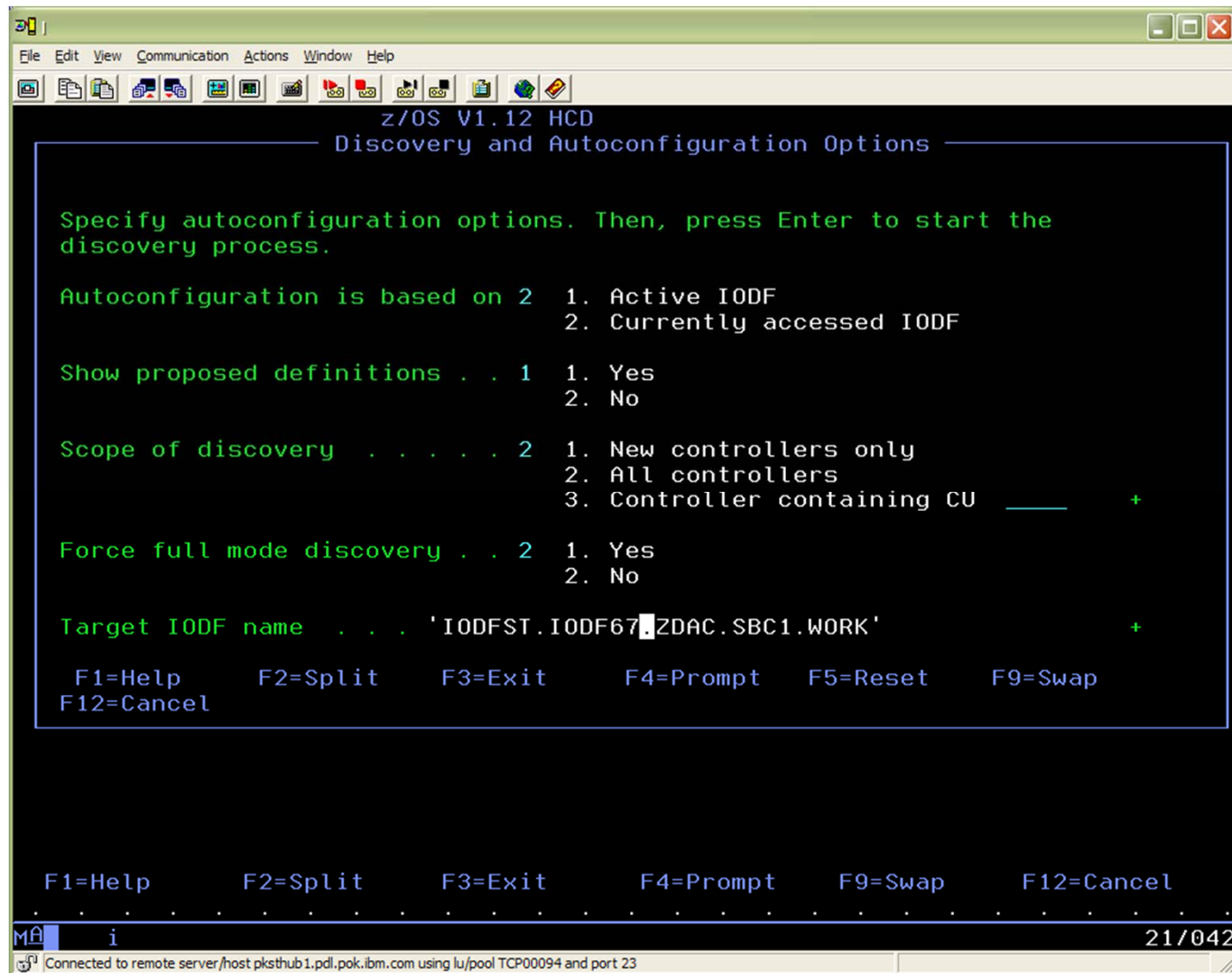

# z/OS Discovery and AutoConfiguration

z/OS V1.12 HCD  
Discovery and Autoconfiguration Options

Discovered New or Changed Controller List

Backup Query Help

Row 1 of 72

Command ==> \_\_\_\_\_ Scroll ==> CSR

Select one or more controllers to be defined, then press Enter.

	Type	Model	Name	Plant	Serial-#	New	Processed	
/	1750	511	IBM	13	AAFGA	Yes	No	
-	1750	511	IBM	13	00438	Yes	No	
-	1750	511	IBM	13	00541	Yes	No	
F	1750	511	IBM	13	40460	Yes	No	
-	1750	511	IBM	68	81071	Yes	No	
-	1750	511	IBM	68	84981	Yes	No	
T	/	2105	F20	IBM	13	12628	Yes	No
-	2105	F20	IBM	13	13901	Yes	No	
-	2105	F20	IBM	13	17533	Yes	No	

F1=Help      F2=Split      F3=Exit      F4=Prompt  
 F7=Backward      F8=Forward      F9=Swap      F10=Actions  
 F12=Cancel      F22=Command

F1=Help      F2=Split      F3=Exit      F4=Prompt      F9=Swap      F12=Cancel

MA i 25/008

Connected to remote server/host pksthub1.pdl.pok.ibm.com using lu/pool TCP00094 and port 23



# z/OS Discovery and AutoConfiguration

z/OS V1.12 HCD  
Discovery and Autoconfiguration Options

S | Backup | Query | Help

Proposed Control Unit List

Row 1 of 16  
Command ==>  Scroll ==> CSR

Control unit type . . : 2105-F20      Serial number : 12628

Proposed switch.ports : 47.70 46.74 47.72 46.7C

To accept the proposed values, press Enter. To modify them, edit the fields, or select one or more control units to change, exclude or include the corresponding definitions, then press Enter.

CU	CU	# of	LPAR	New	Description	I
/	ADD	number+	Access+			
00	8C00	256	M295	Yes	_____	Y
01	8D00	256	M295	Yes	_____	Y
02	9100	256	M295	Yes	_____	Y
03	9200	256	M295	Yes	_____	Y
04	9400	256	M295	Yes	_____	Y
05	9500	256	M295	Yes	_____	Y

F1=Help      F2=Split      F3=Exit      F4=Prompt      F5=Reset  
F7=Backward      F8=Forward      F9=Swap      F12=Cancel      F22=Command

F1=Help      F2=Split      F3=Exit      F4=Prompt      F9=Swap      F12=Cancel

MA i 08/017

Connected to remote server/host pksthub1.pdl.pok.ibm.com using lu/pool TCP00094 and port 23

# z/OS Discovery and AutoConfiguration

```

Proposed Control Unit / Device List                               Row 1 of 16
Command ==>                                      Scroll ==> CSR

Control unit type . . . : 2105-F20          Serial number : 12628

To accept the proposed values, press Enter. To modify them, edit the
fields, or select one or more device ranges to change, exclude or include
the corresponding definitions, then press Enter.

-----Device----- S CU   UA   OS
/ Number  Type+  S Num Range Access+  N Description  I
_ 8C00,256 3390   0 8C00 00-FF ALL      Y _____  Y
_ 8D00,256 3390   0 8D00 00-FF ALL      Y _____  Y
_ 9100,256 3390   0 9100 00-FF ALL      Y _____  Y
_ 9200,256 3390   0 9200 00-FF ALL      Y _____  Y
_ 9400,256 3390   0 9400 00-FF ALL      Y _____  Y
_ 9500,256 3390   0 9500 00-FF ALL      Y _____  Y
_ 9900,256 3390   0 9900 00-FF ALL      Y _____  Y
_ 9A00,256 3390   0 9A00 00-FF ALL      Y _____  Y
_ 9C00,256 3390   0 9C00 00-FF ALL      Y _____  Y
_ 9D00,256 3390   0 9D00 00-FF ALL      Y _____  Y
_ A300,256 3390   0 A300 00-FF ALL      Y _____  Y
_ A700,256 3390   0 A700 00-FF ALL      Y _____  Y
_ A800,256 3390   0 A800 00-FF ALL      Y _____  Y
_ A900,256 3390   0 A900 00-FF ALL      Y _____  Y
_ AA00,256 3390   0 AA00 00-FF ALL      Y _____  Y
_ AB00,256 3390   0 AB00 00-FF ALL      Y _____  Y
***** Bottom of data *****
F1=Help      F2=Split    F3=Exit     F4=Prompt   F5=Reset    F7=Backward
F8=Forward   F9=Swap     F12=Cancel  F22=Command
MA i                                               02/015
Connected to remote server/host.pksthub1.pdl.pok.ibm.com using lu/pool TCP00094 and port 23
    
```

## z/OS Discovery and AutoConfiguration



### ■ Hardware Dependencies

- zDAC uses new capabilities in the z196 or z114 processor for fabric discovery
- Explores FICON channels attached to switches
  - FICON Express8 or FICON Express4 (CHPID type: FC)
- Dynamic I/O Enabled Partitions
- Up to date controller microcode designed to improve discovery performance
  - Tested with IBM 2107 Controller level R12p.9b090910b - Bundle 64.30.87.0
- Controller that registers with the fabric name server
  - All IBM FICON-attached tape and disk supported
- Up to date switch microcode (see notes)
  - Tested with:
    - o Brocade Firmware Version: V6.2.0e
    - o McData Firmware Version : 09.09.00

### ■ Software Dependencies

- All target systems must be at z/OS R1.12 or higher
  - Mixed level SYSPLEXes are allowed, but only z/OS V1.12 (or higher) can participate in discovery processing
- Suggested use of Dynamic Channel path Management (DCM) for performance

## zEnterprise OSA-Express3 Channel Types

- **Two new OSA-Express3 CHPID types to support new types of z196 networks**
- **A z196 or z114 system can have up to 6 types of OSA-Express3 CHPID's**
  - **External (customer managed) networks**
    - Defined as OSC, OSD, OSE, & OSN
    - Existing customer provided and managed OSA ports used for access to the current customer external networks - no changes
  -  – **Intranode management network (INMN)**
    - Defined as CHPID type OSM, OSA-Express for Unified Resource Manager
      - When the PCIe adaptor on 1000BASE-T is defined as CHPID type OSM, the second port cannot be used for anything else
    - OSA-Express3 1000BASE-T configured as CHPID type OSM for connectivity to INMN from z196 or z114 to Unified Resource Manager functions
    - OSA connection via the Bulk Power Hub (BPH) on the zEnterprise to the Top of the Rack (TORs) switches on zBX
  -  – **Intraensemble data networks (IEDN)**
    - Defined as CHPID OSX, OSA-Express for zBX
    - OSA-Express3 10 GbE configured as CHPID type OSX for connectivity and access control to IEDN from z196 or z114 to zBX
- **Functions Supported:**
  - Dynamic I/O support
  - HCD
  - CP Query capabilities
  - Ensemble Management for these new channel paths and their related subchannels.

## OSA-Express3 and OSA-Express4S CHPID Types

CHPID type	Purpose / Traffic	Operating Systems
<b>OSD</b> All OSA features zEnterprise, z10, z9, zSeries	Supports Queue Direct Input/Output (QDIO) architecture TCP/IP traffic when Layer 3 (uses IP address) Protocol-independent when Layer 2 (uses MAC address)	z/OS, z/VM z/VSE, z/TPF Linux on System z
<b>OSE</b> 1000BASE-T zEnterprise, z10, z9, zSeries	Non-QDIO; for SNA/APPN/HPR traffic and TCP/IP "passthru" traffic	z/OS, z/VM z/VSE
<b>OSC</b> 1000BASE-T zEnterprise, z10, z9, z990, z890	OSA-Integrated Console Controller (OSA-ICC) Supports TN3270E, non-SNA DFT to IPL CPCs & LPs	z/OS, z/VM z/VSE
<b>OSM</b> 1000BASE-T zEnterprise exclusive	OSA-Express for Unified Resource Manager Connectivity to intranode management network (INMN) from z196 or z114 to Unified Resource Manager functions	z/OS, z/VM Linux on System z*
<b>OSN</b> GbE, 1000BASE-T zEnterprise, z10, z9 exclusive	OSA-Express for NCP Appears to OS as a device supporting CDLC protocol Enables Network Control Program (NCP) channel-related functions Provides LP-to-LP connectivity OS to IBM Communication Controller for Linux (CCL)	z/OS, z/VM z/VSE, z/TPF Linux on System z
<b>OSX</b> 10 GbE zEnterprise exclusive	OSA-Express for zBX Connectivity and access control to intraensemble data network (IEDN) from z196 or z114 to zBX	z/OS, z/VM Linux on System z*

\*IBM is working with its Linux distribution partners to include support in future Linux on System z distribution releases.

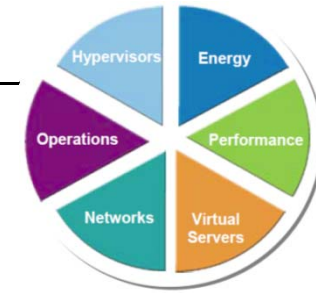

## zEnterprise Ensemble Configuration

- **An Ensemble is a collection of one or more zEnterprise system nodes**
- **An ensemble can consist of:**
  - A single z196 with no zBX attached
  - A single z114 with no zBX attached
  - Two to eight z196 or z114 CPCs where at least one of the CPCs has a zBX attached
- **Ensembles are defined using the HMC**
- **Depending on the System z applications, each ensemble might require:**
  - Intranode management network (INMN)
  - Intraensemble data network (IEDN)
  - Customer managed data network

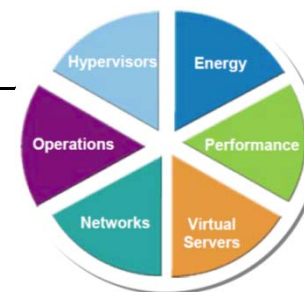

## zEnterprise Ensemble Configuration

### ■ Each Ensemble requires

#### – Customer managed Management Network

- A pair of (Primary & Alternate/Backup) HMCs for the Unified Resource Manager.
- To control and manage the Ensemble.
- Only one pair of Unified Resource Manager HMCs per Ensemble.
- For high availability, one is a mirrored backup, and cannot be used as a Unified Resource Manager HMC, until fail-over
- Both are attached to the Customer Managed Management Network.

### ■ Depending on the System z applications, each ensemble might require: (these are required if there is a zBX present)

#### – Intranode management network

- Used for internal node hardware management. It is provided and managed by IBM
- Connects the CPC's BHPs to the management port of the customer procured switch or the TOR switches in the zBX

#### – Intraensemble data network

- A pair of OSA-Express-3 10 GbE adapters, for redundancy.
- To allow the System z applications to communicate between OS images to share data
- To allow the System z application to communicate to the zBX
- Ensemble zBX to zBX communications.

#### – Customer managed data network

- A pair of 10 Gb connections
- Must provide the MAC address for each device

### ■ External customer networks (example OSC, OSD, OSE, and OSN connections) are outside the ensemble, and not included

# Usage & Invocation (HCD)

```

Session A - [32 x 80]
File Edit View Communication Actions Window Help
Goto Filter Backup Query Help
Add Channel Path

-
C
C
S
Specify or revise the following values.
P
C
C
Processor ID . . . . . : P2817
Configuration mode . . : LPAR
Channel Subsystem ID : 0

Channel path ID . . . . . 43 + PCHID . .
Number of CHPIDs . . . . . 1
Channel path type . . . . . osm +
Operation mode . . . . . span +
Managed . . . . . No (Yes or No) I/O Cluste
Description . . . . .

Specify the following values only if connected to a sw
Dynamic entry switch ID ___ + (00 - FF)
Entry switch ID . . . . . ___ +
Entry port . . . . . ___ +
F1=Help F2=Split F3=Exit F4=Prompt F5=Re

F1=Help F2=Split F3=Exit F4=Prompt F5=Re
F8=Forward F9=Swap F10=Actions F11=Add F12=Ca
F20=Right F22=Command

MA a
Connected to remote server/host tn3270.de.ibm.com using lu/pool FU0U2621 and port 23

```

```

Session A - [32 x 80]
File Edit View Communication Actions Window Help
Goto Filter Backup Query Help
Allow for more than 160 TCP/IP stacks

-
C
C
S
Specify Yes to allow more than 160 TCP/IP stacks,
otherwise specify No. Specifying Yes will cause priority
queuing to be disabled.
P
C
C
Will greater than 160 TCP/IP stacks
be required for this channel? . . . Yes
F1=Help F2=Split F3=Exit F5=Reset F9=Swap
F12=Cancel

/
- 40 OSC SHR ___ ___ No
- 41 OSX SHR ___ ___ No
- 42 OSM SHR ___ ___ No
- 80 FC SPAN 10 10 04 No
- F0 CFP SHR ___ ___ Y No
- F1 CFP SHR ___ ___ Y No
- F2 CFP SHR ___ ___ Y No
***** Bottom of data *****

F1=Help F2=Split F3=Exit F4=Prompt F5=Reset F7=Backward
F8=Forward F9=Swap F10=Actions F11=Add F12=Cancel F13=Instruct
F20=Right F22=Command

MA a
Connected to remote server/host tn3270.de.ibm.com using lu/pool FU0U2621 and port 23

```



## Additional OSA-Express3 Support for z196 or z114

### ■ OSA-Express3

- New display command – D OSAINFO
  - Similar to OSA/SF
- Used to monitor and verify current OSA configuration
- Exclusive to CHPID types OSD, OSM and OSX

### ■ OSA-Express3 Inbound Workload queueing (IWQ)

- Communications Server configuration is required to enable Multiple Inbound Data Queues

**Also available on z10**

## Additional Communications Server Support

### ■ New Communications Server Support

- OSA-Express4S checksum offload for IPv6 and for LPAR to LPAR traffic (both IPv4 and IPv6)
- Large Send for IPv6
- Inbound Workload queueing (IWQ) for Enterprise Extender traffic
- HiperSockets optimization for intraensemble data networks (SoD)

### ■ See z/OS Communications Server New Function Summary *Version 1 Release 13 (GC31-8771)* for:

- Description of the new function
- Restrictions (if any)
- Incompatibilities (if any)
- Dependencies (if any)
- Coexistence requirements (if any)
- Steps to take to implement the function

## OSA-Express4S checksum offload for IPv6 and LPAR to LPAR traffic

### ■ **Restriction:**

- Checksum offload is limited to TCP and UDP packets.
- Checksum offload does not apply to outbound multicast packets.
- Segmentation offload is limited to outbound TCP packets.
- Segmentation offload does not apply to packets that go to another stack that shares the OSA port.
- Checksum offload and segmentation offload do not apply to IPsec-encapsulated packets.
- Checksum offload and segmentation offload do not apply to IPv6 packets that contain extension headers.
- Checksum offload and segmentation offload do not apply when multipath is in effect unless all interfaces in the multipath group provide the same offload capabilities.

### ■ **Dependencies:**

- The checksum offload and segmentation offload enhancements are limited to OSA-Express4S or later Ethernet features that are configured with a CHPID type of OSD or OSX.
- Segmentation offload requires that you enable checksum offload.

### ■ **Using the function:**

- Display whether checksum offload is enabled for an OSA-Express QDIO interface by issuing the Netstat DEvlinks/**-d** command.
- Display whether checksum offload is globally enabled for OSA-Express QDIO IPv4 or IPv6 interfaces by issuing the Netstat CONFIG/**-f** command.
- Display whether segmentation offload is enabled for an OSA-Express QDIO interface by issuing the Netstat DEvlinks/**-d** command.
- Enable IPv6 segmentation offload by specifying the SEGMENTATIONOFFLOAD parameter on the IPCONFIG6 statement.
- Enable IPv4 segmentation offload by specifying the SEGMENTATIONOFFLOAD parameter on the IPCONFIG statement. If the SEGMENTATIONOFFLOAD parameter is specified on the GLOBALCONFIG statement, move this setting to the IPCONFIG statement; this parameter on GLOBALCONFIG is deprecated.
- Display whether segmentation offload is globally enabled for OSA-Express QDIO IPv4 or IPv6 interfaces by issuing the Netstat CONFIG/**-f** command.

## Inbound Workload queueing (IWQ) for Enterprise Extender traffic

### ■ **Restriction:**

- This function is not supported when z/OS V1R13 Communications Server is running as a z/OS guest on z/VM that is using simulated (virtual) devices such as Virtual Switch (VSWITCH) or guest LAN.

### ■ **Incompatibilities:**

- This function is not supported for IPAQENET interfaces that are defined by using the DEVICE, LINK, and HOME statements. Convert your IPAQENET definitions to use the INTERFACE statement to enable this support.

### ■ **Dependencies:**

- This function is limited to OSA-Express3 Ethernet features or later in QDIO mode running on the IBM zEnterprise (z196, z114, or z10 servers).
- This function is supported only for interfaces that are configured to use a virtual MAC (VMAC) address.

### ■ **Using the function:**

- Enable inbound workload queueing for a specific QDIO interface by specifying the WORKLOADQ parameter on the IPAQENET or IPAQENET6 INTERFACE statement (if necessary). For IPv4 QDIO interfaces that are defined by using the DEVICE, LINK, and HOME statements, you must first convert the statement definitions to use an IPAQENET INTERFACE statement.
- Display whether inbound workload queueing is in effect for the QDIO interface by issuing the Netstat DEvlinks/**-d** command.
- Display whether inbound workload queueing is in effect for the QDIO interface and display the workload queueing functions and queue IDs for that interface by issuing the DISPLAY NET,ID=trle command or the DISPLAY NET,TRL,TRLE=trle command.
- Monitor whether inbound traffic is using inbound workload queueing and display statistics for each queue by initiating VTAM tuning statistics for the QDIO interface.
- Monitor whether inbound traffic is using inbound workload queueing and display statistics for each queue by using the TCP/IP callable NMI GetIfStatsExtended request.
- Determine the QID on which a specific packet was received, and the associated workload queueing function, from a packet trace.
- Determine the QID on which a specific packet was received from an OSAENTA trace.

## HiperSockets optimization for intraensemble data networks (SoD)

- **Restriction:**
  - Connectivity to the intraensemble data network is allowed only when the CPC is a member of an ensemble
- **Dependencies:**
  - This function requires an IQD CHPID that is configured with the Internal Queued Direct I/O extensions function (IQDX).
  - This function is dependent on the z/OS LPAR participating in an ensemble. See *zEnterprise System Ensemble Planning and Configuring Guide* for more information.
- **Using the function:**
  - Enable connectivity to the intraensemble data network.
  - Configure an IQD CHPID with the Internal Queued Direct I/O extensions (IQDX) function in Hardware Configuration Definition (HCD).
  - Display whether the stack is enabled for dynamic IQDX interfaces and whether the stack should use these interfaces for large outbound TCP socket data transmissions.
  - Display information about the dynamic IQDX TRLEs and datapath devices by issuing the `DISPLAY NET,ID=trle` or `DISPLAY NET,TRL,TRLE=` command.
  - Display information about an IQDX interface by issuing the `Netstat DEvlinks/-d` command against the IQDX interface.
  - Display information about the number of packets and bytes for an OSX interface that went over the dynamic IQDX interface by issuing the `Netstat DEvlinks/-d` command against the OSX interface.
  - Display the Address Resolution Protocol (ARP) cache entries associated with an IPv4 IQDX interface by issuing the `Netstat ARp/-R` command.
  - Display the neighbor cache entries associated with an IPv6 IQDX interface by issuing the `Netstat ND/-n` command.

## Customization / Activation zManager Performance Management

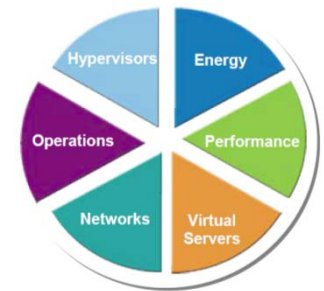

- Create ensemble and add CPC to ensemble
- Configure GPMP
  - The guest platform management provider (GPMP) is the interface between the *zEnterprise* intranode management network (INMN) and the z/OS Workload Manager
  - GPMP provides policy information to WLM about the platform wide performance goals of workloads in which the z/OS is participating
  - WLM supports the GPMP by:
    - configuring the GPMP with the WLM ISPF Application
    - managing the GPMP address space (start, stop, and restart)
    - displaying GPMP status information
    - collecting and aggregating performance measurements
- Start /Stop GPMP

# GPMP Configuration and Management

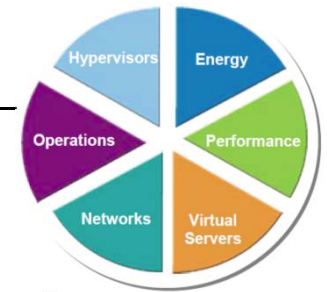

- On **policy activation**
  - WLM checks whether the service definition has valid GPMP settings
  - If activate=yes and system name not specified on excluded-list, GPMP is started automatically
- Also, you can use the **MODIFY WLM** command. The syntax of the command is:
  - **F WLM,GPMP,START**
    - Indicates that you want to start the GPMP
  - **F WLM,GPMP,STOP**
    - Indicates that WLM stops the currently active GPMP instance
  - **F WLM,GPMP,TRACE=NONE|LOW|MEDIUM|HIGH,DEST=FILE|MEMORY**
    - Enables you to change the GPMP internal tracing level “on the fly” and to change the destination of the trace (file or memory)
- Once you stopped the GPMP manually, the GPMP switches into “manual mode”. It is not automatically restarted even if a WLM policy with a valid GPMP configuration gets activated

## General Recommendations and Considerations

- **z196 and z114 are based on existing System z technology**
  - z/Architecture (z900/z800)
  - Multiple Logical Channel Subsystems (z990/z890)
  - OSA-Express2, FICON Express4, Crypto Express2 (z9 EC/z9 BC)
  - HiperDispatch, Large Page, zHPF (z10 EC, z10 BC)
- **z196 and z114 capabilities differ depending on z/OS release**
  - Web deliverables are needed for some functions on some releases
- **Don't migrate software releases and hardware at the same time**
- **Migrate to STP or Mixed-CTN network prior to introducing a z196 or z114 into a sysplex**
- **Keep members of the sysplex at the same software level other than during brief migration periods**
- **Review any restrictions and migration considerations prior to creating upgrade plan**



## SMP/E V3.5's support for FIXCAT HOLDDATA For Hardware PSP Bucket Verification

- A new HOLDDATA type FIXCAT (fix category) to associate an APAR to a particular category of fix

```
++HOLD(HBB7770) FMID(HBB7770) REASON(AA32478) FIXCAT  
CATEGORY(IBM.Device.Server.z196-2817) RESOLVER(UA54038) .
```

- A SOURCEID of the FIXCAT name will be added by SMP/E to the resolving PTF
- This SOURCEID can be used on APPLY or ACCEPT commands
  - If **ALL available applicable PTFs RECEIVED**, can use **APPLY CHECK** to identify what needs to be installed

```
SET BDY(ZOS19T).  
APPLY CHECK GROUPEXTEND BYPASS(HOLDSYS)  
SOURCEID(IBM.Device.Server.*2817*,IBM.Device.Server.zBX*).
```

- New REPORT MISSINGFIX command can be used to identify what needs to be installed, even if the PTFs are not yet RECEIVED

```
SET BDY(GLOBAL).  
REPORT MISSINGFIX ZONES(ZOS19T)  
FIXCAT(IBM.Device.Server.*2817*,IBM.Device.Server.zBX*) .
```

# Typical z/OS V1.8 - z/OS V1.9 Migration Path

Cryptographic Support for z/OS VR9  
through z/OS V1R11 Web Deliverable

(HCR7770<sup>2,3,4</sup>)

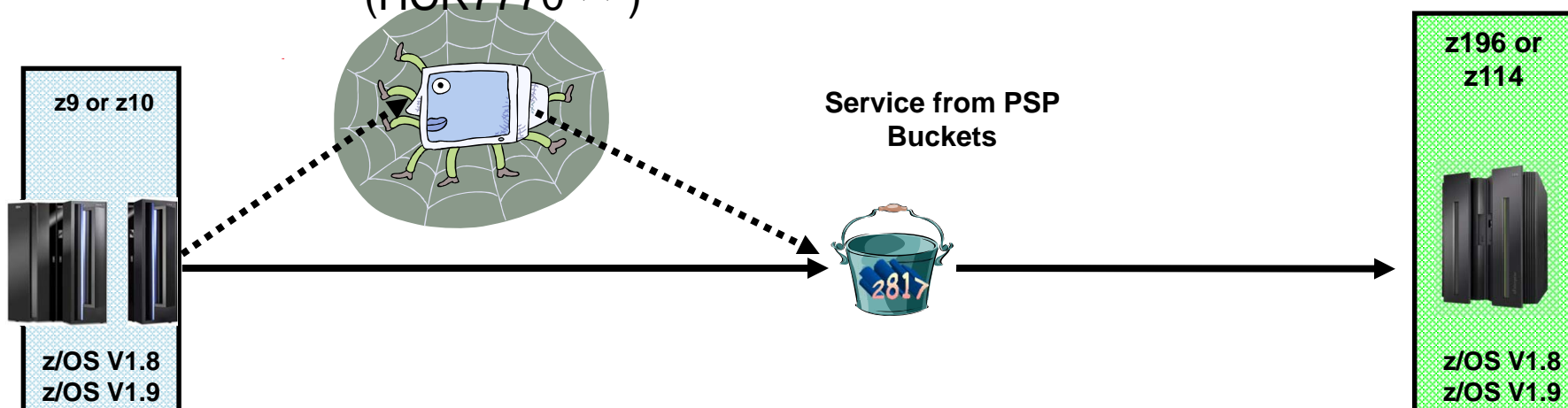

## Notes:

1. Toleration PTF is needed for all possible ICSF levels
2. If you require Crypto Advanced Encryption Standard (AES) for 256-bit keys SHA-384 and 512 bit for message digest support, ISO Format 3 PIN blocks, support for RSA keys up to 4096 bits, Random Number Generator Long, or enhanced TKE Auditing, then you must install the Cryptographic Support for z/OS V1R7-V1R9 and z/OS.e V1R7-V1R8 Web Deliverable (or higher).
3. If you require Support for 13- thru 19-digit Personal Account Numbers, ICSF Query Algorithms, or Key Token Policy support then you must install the Cryptographic Support for z/OS V1.8 through z/OS V1.10 and z/OS.e V1.8 Web deliverable (or higher)
4. For z/OS V1.9, if you require protected key CP Assist for Cryptographic Function, new Crypto Express3 or Crypto Express3 -1P, then you must install the Cryptographic Support for z/OS V1R9-V1R11 Web deliverable

# Typical z/OS V1.10 thru z/OS V1.13 Migration Path

Cryptographic Support for z/OS V1R11  
through z/OS V1R13 Web Deliverable

(HCR7790<sup>2,3,4,5</sup>)

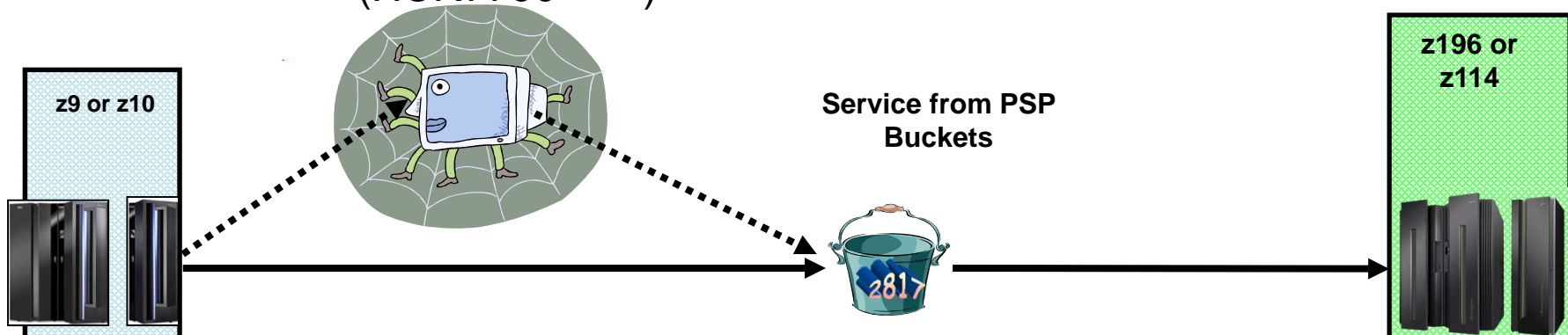

## Notes:

1. Toleration PTF is needed for lower ICSF levels, exploitation is provided via the Cryptographic Support for z/OS V1R10-V1R12 Web deliverable For z/OS V1.10, if you require Support for 13- thru 19-digit Personal Account Numbers, ICSF Query Algorithms, or Key Token Policy support then you must install the Cryptographic Support for z/OS V1.8 through z/OS V1.10 and z/OS.e V1.8 Web deliverable (or higher)
2. For z/OS V1.10 or z/OS V1.11, if you require protected key CP Assist for Cryptographic Function, new Crypto Express3 or Crypto Express3 -1P, then you must install the Cryptographic Support for z/OS V1R9-V1R11 Web deliverable (or higher)
3. If you require X9.8 Pin, 64 Bit, zEnterprise (z196 or z114) CPACF, HMAC, CKDS Constraint Relief, PCI Audit, ECC HW Support, CBC Key Wrap, and PKA RSA OAEP with SHA-256 algorithm, then you must install the Cryptographic Support for z/OS V1R10-V1R12 Web deliverable (or higher)
4. For z/OS V1.11 or higher, if you require Expanded key support for AES algorithm, enhanced ANSI TR-31 Secure Key Exchange, PIN block decimalization table protection, PKA RSA OAEP with SHA-256 algorithm, or additional Elliptic Curve Cryptography (ECC) functions then you must install the Cryptographic Support for z/OS V1R10-V1R12 Web deliverable (planned availability September 2011)



# Summary

## Supported IBM zEnterprise System Migration Scenarios

- 1. Existing System z server to new z196 or z114 server**
  - Toleration versus exploitation differs by release
  - ICSF web deliverable needed for function required
- 2. Existing z9 or z10 sysplex replaced by z196 or z114 (or z196/z114 added to existing sysplex)**
  - Coupling Link technology (no ICB-4 to z196 or z114)
  - Only STP or Mixed CTN supported (no ETR connections to a z196 or z114)
- 3. All existing z9 or z10 z/OS images replaced by z196 or z114 images**
  - If you want an ensemble
    - z/OS releases must be z/OS V1.10 or higher
    - Configure an Ensemble from the HMC
- 4. Exploit a z196 or z114 with zBX using IBM Blades**
  - z/OS releases must be z/OS V1.10 or higher
  - Configure OSM OSA CHPIDs for Intranode Management Network (INMN)
  - Configure OSX OSA CHPIDs for Intraensemble Data Networks (IEDN)
  - User responsible for AIX OS and application provisioning
- 5. Exploit z196 or z114 with zBX using IBM Smart Analytics Optimizer**
  - z/OS releases must be z/OS V1.10 or higher; DB2 releases V9.1 or higher
  - Configure OSM OSA CHPIDs for Intranode Management Network (INMN)
  - Configure OSX OSA CHPIDs for Intraensemble Data Networks (IEDN)

## z/OS Software Positioning for a zEnterprise (z196 or z114) Server

# Summary: z/OS Software Support for IBM zEnterprise (z196 or z114)

### z/OS V1.8 and higher

- OSA-Express3 (GbE LX and SX, 1000BASE-T, 10 GbE LR and SR)
- FICON Express8
- **PCIe-based I/O Infrastructure – FICON Express8S and OSA Express4S**
- New z/Architecture Instructions (and new OPCode support)
- InfiniBand Coupling Links
- HiperDispatch cache and affinity node changes
- IFAURP Reporting
- Toleration for >64 CPs on the server
- OSA-Express3 (CHPID Type OSD) with or without exploitation of two ports per CHPID
- Crypto toleration



### z/OS V1.10 and higher

- zBX support for the IBM Smart Analytics Optimizer for DB2 for z/OS, V1.1 (5697-AQT), the IBM WebSphere DataPower Integration Appliance XI50 for zEnterprise (DataPower XI50z), and select POWER7 and IBM System x blades
- IBM zEnterprise Unified Resource Manager
  - Network and Performance Management
  - Intranode Management Network (INMN) and Intraensemble data network (IEDN)
- HiperDispatch performance and serviceability enhancements
- Static Power Save Mode (z196 only)
- Language Environment High Register Resolution
- CPU Measurement Facility (Hardware Instrumentation Services)
- CF Level 17
- Removal of the 64k byte data transfer limit for zHPF multitrack operations
- Greater than 64 CPs per LPAR
- Up to 32 HiperSockets
- Three subchannel sets
- Crypto Exploitation (ANSI X9.8 Pin security, enhanced Common Cryptographic Architecture (CCA), 64 Bit, CP Assist for Cryptographic Function (CPACF) enhancements, Secure Keyed-Hash Message Authentication Code (HMAC), CKDS Constraint Relief, PCI Audit, Elliptical Curve Cryptography (ECC) Digital Signature Algorithm, CBC Key Wrap, and **PKA RSA OAEP with SHA-256 algorithm**)
- RMF Postprocessor Crypto Activity report support for 4096-bit



### z/OS V1.11 and higher

- **IPL for alternate subchannel set**
- **zHPF Performance improvements for FICON Express 8S**
- **Crypto Exploitation**
  - **z/OS V1.11-z/OS V1.13: Expanded key support for AES algorithm, enhanced ANSI TR-31 Secure Key Exchange, PIN block decimalization table protection, PKA RSA OAEP with SHA-256 algorithm, and additional Elliptic Curve Cryptography (ECC) functions.**

### z/OS V1.12 and higher

- XL C/C++ ARCH(9) and Tune(9) Options
- zDAC support
- New display command – D OSAINFO
- OSA-Express3 Inbound Workload queueing (IWQ)
- Nondisruptive CF Dump

### z/OS V1.13 only

- **OSA-Express4S checksum offload for IPv6**
- **OSA-Express4S checksum offload for LPAR to LPAR traffic (both IPv4 and IPv6)**
- **Large Send for IPv6**
- **Inbound Workload queueing (IWQ) for Enterprise Extender traffic**
- **HiperSockets optimization for intraensemble data networks (Sd)**





**Backup  
Material**



## Additional Information

- **z/OS Home Page**  
<http://www.ibm.com/servers/eserver/zseries/zos/>
- **zFavorites for System z**  
<http://www.ibm.com/servers/eserver/zseries/zos/zfavorites/>
- **z/OS Internet Library**  
<http://www.ibm.com/servers/eserver/zseries/zos/bkserv/>
- **IBM System z**  
<http://www.ibm.com/systems/z/>
- **IBM Resource Link**  
<https://app-06.www.ibm.com/servers/resourcelink/hom03010.nsf>
- **IBM Redbooks – How-To Books (also Redpieces)**  
<http://www.redbooks.ibm.com/>
- **Preventive Service Planning buckets**  
<http://www14.software.ibm.com/webapp/set2/psp/srchBroker>
- **Enhanced HOLDDATA**  
<http://service.boulder.ibm.com/390holddata.html>



## z/OS Software Positioning for a zEnterprise (z196 or z114) Server

# Trademarks

**The following are trademarks of the International Business Machines Corporation in the United States and/or other countries.**

BladeCenter*	HiperSockets	Language Environment*	Redbooks*	SystemPac*	System z10	z10 BC
DB2*	IBM*	Parallel Sysplex*	RMF	System Storage*	System z10 Business Class	z10 EC
ESCON*	IBM (logo)	POWER7	ServerPac*	System z	z/Architecture*	z/OS*
FICON Express*	Infiniband*	RACF*	Sysplex Timer*	System z9	z9*	zEnterprise
					z10	zSeries*

\* Registered trademarks of IBM Corporation

**The following are trademarks or registered trademarks of other companies.**

Adobe, the Adobe logo, PostScript, and the PostScript logo are either registered trademarks or trademarks of Adobe Systems Incorporated in the United States, and/or other countries.

Firefox is a trademark of Mozilla Foundation

Cell Broadband Engine is a trademark of Sony Computer Entertainment, Inc. in the United States, other countries, or both and is used under license there from.

Java and all Java-based trademarks and logos are trademarks or registered trademarks of Oracle and/or its affiliates in the United States, other countries, or both.

Microsoft, Windows, Windows NT, and the Windows logo are trademarks of Microsoft Corporation in the United States, other countries, or both.

Internet Explorer is a trademark of Microsoft Corp

InfiniBand is a trademark and service mark of the InfiniBand Trade Association.

Intel, Intel logo, Intel Inside, Intel Inside logo, Intel Centrino, Intel Centrino logo, Celeron, Intel Xeon, Intel SpeedStep, Itanium, and Pentium are trademarks or registered trademarks of Intel Corporation or its subsidiaries in the United States and other countries.

UNIX is a registered trademark of The Open Group in the United States and other countries.

Linux is a registered trademark of Linus Torvalds in the United States, other countries, or both.

ITIL is a registered trademark, and a registered community trademark of the Office of Government Commerce, and is registered in the U.S. Patent and Trademark Office.

IT Infrastructure Library is a registered trademark of the Central Computer and Telecommunications Agency, which is now part of the Office of Government Commerce.

\* All other products may be trademarks or registered trademarks of their respective companies.

### Notes:

Performance is in Internal Throughput Rate (ITR) ratio based on measurements and projections using standard IBM benchmarks in a controlled environment. The actual throughput that any user will experience will vary depending upon considerations such as the amount of multiprogramming in the user's job stream, the I/O configuration, the storage configuration, and the workload processed. Therefore, no assurance can be given that an individual user will achieve throughput improvements equivalent to the performance ratios stated here.

IBM hardware products are manufactured from new parts, or new and serviceable used parts. Regardless, our warranty terms apply.

All customer examples cited or described in this presentation are presented as illustrations of the manner in which some customers have used IBM products and the results they may have achieved. Actual environmental costs and performance characteristics will vary depending on individual customer configurations and conditions.

This publication was produced in the United States. IBM may not offer the products, services or features discussed in this document in other countries, and the information may be subject to change without notice. Consult your local IBM business contact for information on the product or services available in your area.

All statements regarding IBM's future direction and intent are subject to change or withdrawal without notice, and represent goals and objectives only.

Information about non-IBM products is obtained from the manufacturers of those products or their published announcements. IBM has not tested those products and cannot confirm the performance, compatibility, or any other claims related to non-IBM products. Questions on the capabilities of non-IBM products should be addressed to the suppliers of those products.

Prices subject to change without notice. Contact your IBM representative or Business Partner for the most current pricing in your geography.

See url <http://www.ibm.com/legal/copytrade.shtml> for a list of IBM trademarks.

**z/OS Support  
For z10 Servers**

# z/OS Support Summary for z10 Support

- **z/OS V1.7 (with the IBM Lifecycle Extension for z/OS V1.7)**
  - Parallel Sysplex InfiniBand (PSIFB) Coupling Links
  - OSA-Express3 10 Gigabit Ethernet
  - 65535 MP Factors
  - Crypto Toleration
    - CP Assist for Cryptographic Functions and Configurable Crypto Express2, Remote loading of ATM and Point of Sale (POS) keys,...
  - Crypto Exploitation
    - Crypto Advanced Encryption Standard (AES) for 192-bit and 256-bit keys, SHA-384 and 512 bit for message digest support, RSA keys up to 4096 bits in Length, Dynamically Add Crypto to Logical Partition, Support for 13-19 digit PANs data, Secure Key AES Support ...
  - HiperDispatch (Requires zIIP Web Deliverable to be installed (but not a zIIP processor))
  - Decimal Floating Point (High Level Assembler support only)
  - High Performance FICON
  - CF Level 16
- **z/OS V1.8 and z/OS.e V1.8 (with the IBM Lifecycle Extension for z/OS V1.8)**
  - Large Memory > 128GB (up to 1 TB on z10 EC)
  - Additional support for Decimal Floating Point (HLASM, LE, DBX, and CDA RTLE)
    - XL C/C++ support if you download and install the z/OS V1.9 XL C/C++ Compiler
  - OSA-Express3 Double Port Density
  - CPU Measurement Facility
  - Worldwide port name (WWPN) tool for advance SAN preplanning
- **z/OS V1.9**
  - Additional support for Decimal Floating Point (XL C/C++ Compiler)
  - z/OS XL C/C++ Exploitation of z10 EC Machine Instructions
  - Greater than 54 CPs for a single LPAR
  - Large Page Support
  - Capacity Provisioning
  - RMF FICON Enhancements
  - HiperSockets Multiple Write Facility
  - OSA-Express3 Double Port Density
  - STP Enhancements
- **z/OS V1.10**
  - Dynamic add logical CPs
- **z/OS V1.11**
  - New XL C/C++ Compiler Options
  - Large Page Support in Language Environment
  - BCPii Activation Profile Support





z/OS Software Positioning for a zEnterprise (z10 or z114) Server 2098DEVICE 2098/ZOS

Release	Included in Base z/OS Support										Explicit z/OS Support																						
	z10 EC GA1 Support	OSA-Express3 10 GbE	OSA-Express3 4-port OSA-ICC	65535 MP Factors	z10 mnemonic support	Crypto Toleration <sup>1</sup>	HiperDispatch	Large Memory > 128GB (1 TB) <sup>2</sup>	C/C++ ARCH(8) and TUNE(8)	Greater than 54 CPs (64) <sup>3</sup>	Dynam. Add Logical CPs	PSIFB Coupling Links	Usage Report Program	Decimal Floating Point <sup>4</sup>	High Performance FICON	CF Level 16	Crypto Exploitation <sup>5</sup>	Layer 3 VMAC Support	Service Aids Support for Large Dumps	CPU Measurement Facility	OSA-Express3 Double Port Density	WWPN prediction tool	Large Page Support	Capacity Provisioning	HiperSockets Multiple Write Facility	STP Enhancements	Protected Key CPACF	OSA Optimized Latency Mode (OLM)	OSA QDIO data connection Isolation	New XL C/C++ Compiler Options	BCPII Activation Profile		
z/OS 1.7 <sup>6</sup>	P	B	B	P	P	W P	N	N	N	N	P	P	P	P	P	W	N	N	N	N	N	N	N	N	N	N	N	N	N	N	N	N	
z/OS 1.7 <sup>6</sup> w/ZIIP	P	B	B	P	P	W P	W P	N	N	N	P	P	P	P	P	W	N	N	N	N	N	N	N	N	N	N	N	N	N	N	N	N	
z/OS 1.8 <sup>6</sup>	P	B	B	P	P	B P	P P	W P	N	N	P	P	W P	P	P	W	P	P	P	P	P	N	N	N	N	N	N	N	N	N	N	N	
z/OS 1.9	P	B	B	B	P	B P	B P	B P	B	B	N	B P	P P	P	P	W	B	P	P	P	P	P	B P	B P	P	P	W P	N	N	N	N	N	
z/OS 1.10	P	B	B	B	B	B P	B P	B P	B	B	B	B P	P P	P	P	W	B	B	P	B	P	P	B P	B P	B	P	W P	N	N	N	N	N	
z/OS 1.11	P	B	B	B	B	B P	B P	B P	B	B	B	B P	P P	P	P	W	B	B	B	B	B	B	B P	B P	B	B	B	W P	P	P	P	P	P

- 1 – New cryptographic toleration required for GA3 (Y4)
- 2 - Up to 1 Terabyte on a z10 EC, and up to 248 GB on a z10 BC
- 3 – Only on a z10 EC
- 4 – Decimal Floating Point Support differs by release

- 5 – Crypto Exploitation differs by release and web deliverable installed
- 6 - The IBM Lifecycle Extension for z/OS is required after Sept. 2009



**ICSF**



## z/OS Software Positioning for a zEnterprise (z196 or z114) Server

Operating System	Level Shipped in Base Product	Level Required for Secure or Clear Key or Enhanced Secure Key Support and 64 bit addressing caller support	Level Required for AES, PRNG, and SHA-256 and CEX2n exploitation	Level required for Remote Key Loading for ATMs and POSs	Level Required for 4096-RSA keys, ISO-3 PIN Support	Level Required for CPACF support for SHA-384 and SHA-512 Support	Level Required for 13- thru 19-digit Personal Account Numbers, ICSF Query Algorithms, Secure Key AES and Key Token Policy support	Crypto Express3, Crypto Express3 1P, and Protected Key CPACF	X9.8 Pin, 64 Bit, z196/ z114 CPACF, HMAC, CKDS Constraint Relief, AP Interrupt, PCI Audit, ECC HW Support, CBC Key Wrap, PKA RSA OAEP with SHA-256 algorithm	Expanded key support for AES algorithm, enhanced ANSI TR-31 Secure Key Exchange, PIN block decimalization table protection, PKA RSA OAEP with SHA-256 algorithm, and additional ECC functions
z/OS V1.8 <sup>1</sup>	HCR7731	Integrated in z/OS base level	Integrated in z/OS base level	Integrated in z/OS base level	HCR7750	HCR7750	HCR7751	N/A	N/A	N/A
z/OS V1.9 <sup>1</sup>	HCR7740	Integrated in z/OS base level	Integrated in z/OS base level	Integrated in z/OS base level	HCR7750	HCR7750	HCR7751	HCR7770	N/A	N/A
z/OS V1.10 <sup>1</sup>	HCR7750	Integrated in z/OS base level	Integrated in z/OS base level	Integrated in z/OS base level	Integrated in z/OS base level	Integrated in z/OS base level	HCR7751	HCR7770	HCR7780	N/A
z/OS V1.11	HCR7751	Integrated in z/OS base level	Integrated in z/OS base level	Integrated in z/OS base level	Integrated in z/OS base level	Integrated in z/OS base level	Integrated in z/OS base level	HCR7770	HCR7780	HCR7790
z/OS V1.12	HCR7770	Integrated in z/OS base level	Integrated in z/OS base level	Integrated in z/OS base level	Integrated in z/OS base level	Integrated in z/OS base level	Integrated in z/OS base level	Integrated in z/OS base level	HCR7780	HCR7790
z/OS V1.13	HCR7780	Integrated in z/OS base level	Integrated in z/OS base level	Integrated in z/OS base level	Integrated in z/OS base level	Integrated in z/OS base level	Integrated in z/OS base level	Integrated in z/OS base level	Integrated in z/OS base level	HCR7790

<sup>1</sup> The IBM Lifecycle Extension for z/OS is required for support after general support is withdrawn

## z/OS Crypto Toleration Support

z/OS Release	Crypto Web Download	FMID	Comments
z/OS V1.8 <sup>1</sup>	N/A – In z/OS base product	HCR7731	CPACF and Crypto Express2 exploitation, enhancements include Remote Key Loading for ATMs and POSs
	[11/2007] Cryptographic Support for z/OS V1R7-V1R9 and z/OS.e V1R7-V1R8 web deliverable	HCR7750	4096-bit RSA keys, ISO-3 PIN Support, CPACF support for SHA-394 and SHA-512, Reduced support of retained private key in ICSF
	[11/2008] Cryptographic Support for z/OS V1.8 through z/OS V1.10 and z/OS.e V1.8 web deliverable	HCR7751	Support for 13- thru 19-digit Personal Account Numbers, ICSF Query Algorithms, Key Token Policy support, and Secure Key AES
z/OS V1.9 <sup>1</sup>	N/A – In z/OS base product	HCR7740	PKCS11 Support
	[11/2007] Cryptographic Support for z/OS V1R7-V1R9 and z/OS.e V1R7-V1R8 web deliverable	HCR7750	4096-bit RSA keys, ISO-3 PIN Support, CPACF support for SHA-394 and SHA-512, Reduced support of retained private key in ICSF
	[11/2008] Cryptographic Support for z/OS V1.8 through z/OS V1.10 and z/OS.e V1.8 web deliverable	HCR7751	Support for 13- thru 19-digit Personal Account Numbers, ICSF Query Algorithms, Key Token Policy support, and Secure Key AES
	[11/2009] Cryptographic Support for z/OS V1R9-V1R11 Web deliverable	HCR7770	Protected Key CP Assist for Cryptographic Function, and new Crypto Express3 and Crypto Express3 - 1P

<sup>1</sup> The IBM Lifecycle Extension for z/OS is required for support after general support is withdrawn



## z/OS Crypto Exploitation Support (1 of 2)

z/OS Release	Crypto Web Download	FMID	Comments
z/OS V1.10	N/A – In z/OS base product	HCR7750	Prior release plus: 4096-bit RSA keys, ISO-3 PIN Support, CPACF support for SHA-394 and SHA-512, Reduced support of retained private key in ICSF
	[11/2008] Cryptographic Support for z/OS V1.8 through z/OS V1.10 and z/OS.e V1.8 web deliverable	HCR7751	Support for 13- thru 19-digit Personal Account Numbers, ICSF Query Algorithms, Key Token Policy support, and Secure Key AES
	[11/2009] Cryptographic Support for z/OS V1R9-V1R11 Web deliverable	HCR7770	Protected Key CP Assist for Cryptographic Function and new Crypto Express3 and Crypto Express3 -1P
	[9/2010] Cryptographic Support for z/OS V1R10-V1R12 Web deliverable	HCR7780	X9.8 Pin, 64 Bit, z196/z114 CPACF, HMAC*, CKDS Constraint Relief, AP Interrupt, PCI Audit, ECC HW Support, CBC Key Wrap, and PKA RSA OAEP with SHA-256 algorithm
z/OS V1.11	N/A – In z/OS base product	HCR7751	Prior release plus: Support for 13- thru 19-digit Personal Account Numbers, ICSF Query Algorithms, Key Token Policy support, and Secure Key AES
	[11/2009] Cryptographic Support for z/OS V1R9-V1R11 Web deliverable	HCR7770	Protected Key CP Assist for Cryptographic Function and new Crypto Express3 and Crypto Express3 -1P
	[9/2010] Cryptographic Support for z/OS V1R10-V1R12 Web deliverable	HCR7780	X9.8 Pin, 64 Bit, z196/z114 CPACF, HMAC*, CKDS Constraint Relief, AP Interrupt, PCI Audit, ECC HW Support, CBC Key Wrap, and PKA RSA OAEP with SHA-256 algorithm
	[9/2011] Cryptographic Support for z/OS V1R11-V1R13 Web deliverable	HCR7790	Expanded key support for AES algorithm, enhanced ANSI TR-31 Secure Key Exchange, PIN block decimalization table protection, PKA RSA OAEP with SHA-256 algorithm, and additional Elliptic Curve Cryptography (ECC) functions.

## z/OS Crypto Exploitation Support (2 of 2)

z/OS Release	Crypto Web Download	FMID	Comments
z/OS V1.12	N/A – In z/OS base product	HCR7770	Prior release plus: Protected Key CP Assist for Cryptographic Function and new Crypto Express3 and Crypto Express3 -1P
	[9/2010] Cryptographic Support for z/OS V1R10-V1R12 Web deliverable	HCR7780	X9.8 Pin, 64 Bit, z196/z114 CPACF, HMAC*, CKDS Constraint Relief, AP Interrupt, PCI Audit, ECC HW Support, CBC Key Wrap, and PKA RSA OAEP with SHA-256 algorithm
	[9/2011] Cryptographic Support for z/OS V1R11-V1R13 Web deliverable	HCR7790	Expanded key support for AES algorithm, enhanced ANSI TR-31 Secure Key Exchange, PIN block decimalization table protection, PKA RSA OAEP with SHA-256 algorithm, and additional Elliptic Curve Cryptography (ECC) functions.
z/OS V1.13	N/A – In z/OS base product	HCR7780	Prior release plus: X9.8 Pin, 64 Bit, z196/z114 CPACF, HMAC*, CKDS Constraint Relief, AP Interrupt, PCI Audit, ECC HW Support, CBC Key Wrap, and PKA RSA OAEP with SHA-256 algorithm
	[9/2011] Cryptographic Support for z/OS V1R11-V1R13 Web deliverable	HCR7790	Expanded key support for AES algorithm, enhanced ANSI TR-31 Secure Key Exchange, PIN block decimalization table protection, PKA RSA OAEP with SHA-256 algorithm, additional and Elliptic Curve Cryptography (ECC) functions.



## z/OS Software Positioning for a zEnterprise (z196 or z114) Server

External Name	FMID	Applicable z/OS Releases	Avail	EoM
z/OS or z/OS.e V1.3 or V1.4	HCR7706	z/OS V1.3 and z/OS V1.4	3/2002	9/2004
z990 Cryptographic CP Assist Support for z/OS V1.3 <sup>1</sup>	HCR7708	z/OS V1.3	6/2003	10/2003
z/OS V1.4 z990 Compatibility Support or z/OS.e z990 Coexistence	HCR7708	z/OS V1.4	6/2003	10/2003
z/OS V1.4 z990 Exploitation Support or z/OS.e Coexistence Update feature	HCR7708	z/OS V1.4	10/2003	12/2006
z990 Cryptographic Support <sup>2</sup>	HCR770A	OS/390 V2.10, z/OS 1.2, z/OS 1.3, z/OS V1.4, any z/OS V1.4 features, and z/OS V1.5	9/2003	5/2004
z/OS or z/OS.e V1.5	HCR7708	z/OS V1.5	3/2004	9/2004
z/OS or z/OS.e V1.6	HCR770A	z/OS V1.6	9/2004	10/2005
z990 and z890 Enhancements to Cryptographic Support <sup>3</sup>	HCR770B	OS/390 V2.10, z/OS V1.2, z/OS V1.3, z/OS V1.4 and z/OS V1.5	5/2004	12/2006
ICSF 64-bit Virtual Support for Z/OS V1.6 and z/OS.e V1.6 <sup>4</sup>	HCR7720	z/OS V1.6	12/2004	9/2005
z/OS or z/OS.e V1.7	HCR7720	z/OS V1.7	9/2005	10/2006
Cryptographic Support for z/OS V1R6/R7 and z/OS.e V1R6/R7 <sup>5</sup>	HCR7730	z/OS V1.6 and z/OS V1.7	9/2005	5/2006
Enhancements to Cryptographic Support for z/OS and z/OS.e V1R6/R7 <sup>6</sup>	HCR7731	z/OS V1.6 and z/OS V1.7	5/2006	11/2007
z/OS or z/OS.e V1.8	HCR7731	z/OS V1.8	9/2006	10/2007
z/OS V1.9	HCR7740	z/OS V1.9	9/2007	10/2008
Cryptographic Support for z/OS V1R7-V1R9 and z/OS.e V1R7-V1R8 web deliverable <sup>7</sup>	HCR7750	z/OS V1.7, z/OS V1.8 and z/OS V1.9	9/2007	11/2008
z/OS V1.10	HCR7750	z/OS V1.10	9/2008	10/2009
Cryptographic Support for z/OS V1.8 through z/OS V1.10 and z/OS.e V1.8 web deliverable <sup>8</sup>	HCR7751	z/OS V1.7*, z/OS V1.8, z/OS V1.9, z/OS V1.10	11/2008	11/2009
z/OS V1.11	HCR7751	z/OS V1.11	9/2009	10/2010
Cryptographic Support for z/OS V1R9-V1R11 Web deliverable <sup>9</sup>	HCR7770	z/OS V1.9, z/OS V1.10, z/OS V1.11	11/2009	9/2010
z/OS V1.12	HCR7770	z/OS V1.12	9/2010	10/2011
Cryptographic Support for z/OS V1R10-V1R12 Web deliverable <sup>10</sup>	HCR7780	z/OS V1.10, z/OS V1.11, z/OS V1.12	9/2010	9/2011
z/OS V1.13	HCR7780	z/OS V1.13	9/2011	10/2011
Cryptographic Support for z/OS V1R10-V1R12 Web deliverable <sup>11</sup>	HCR7790	z/OS V1.11, z/OS V1.12, z/OS V1.13	9/2011	TBD

# STP Planning

## STP References and Additional Information



### ■ Redbooks

- Server Time Protocol Planning Guide, SG24-7280
  - <http://www.redbooks.ibm.com/redpieces/abstracts/sg247280.html>
- Server Time Protocol Implementation Guide, SG24-7281
  - <http://www.redbooks.ibm.com/redpieces/abstracts/sg247281.html>

### ■ Education

- Introduction to Server Time Protocol (STP)
  - Available on Resource Link at General Availability (GA)
  - [www.ibm.com/servers/resourcelink/hom03010.nsf?OpenDatabase](http://www.ibm.com/servers/resourcelink/hom03010.nsf?OpenDatabase)

### ■ STP Web site

- [www.ibm.com/systems/z/pso/stp.html](http://www.ibm.com/systems/z/pso/stp.html)

### ■ Systems Assurance

- The IBM team is required to complete a Systems Assurance Review (SAPR Guide, SA06-012) and to complete the Systems Assurance Confirmation Form via Resource Link
- <http://w3-03.ibm.com/support/assure/assur30i.nsf/WebIndex/SA779>



zEnd



**The Future Runs on System z**